

C
10.5"
267

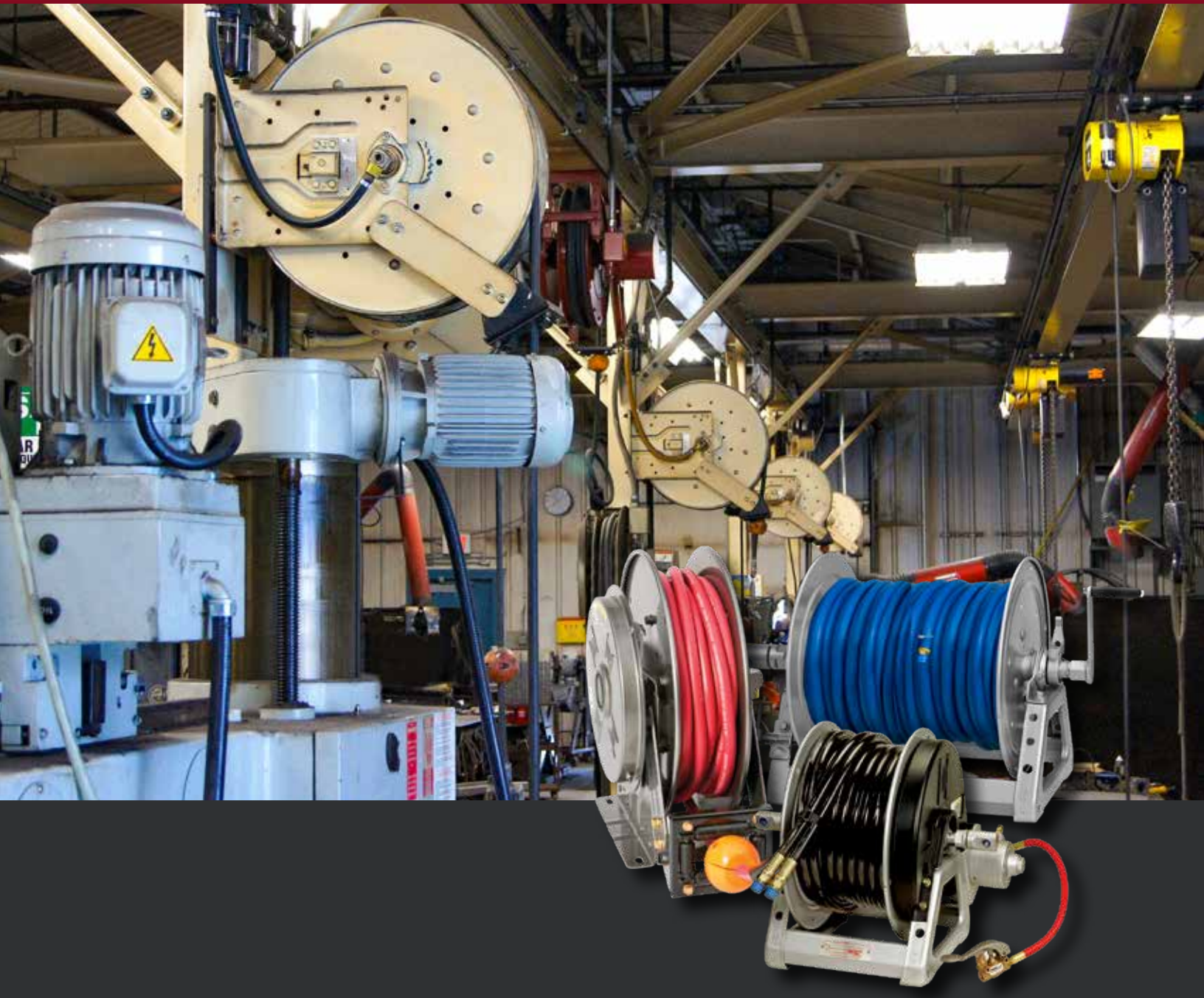

Industrial Hose Reels

- | Washdown | Chemical Transfer | Potable Water | Food & Beverage Processing |
- | Pharmaceuticals & Cosmetics | Fueling | Fire Protection | Assembly Operations |
- | Air or Water Supply | Cable & Hose Storage | Hydraulic & Pneumatic Tools |



Family owned and operated since 1933

CONTENTS

Hannay hose reels come in all sizes and capacities.

Hannay Reels is the leading manufacturer of high quality hose and cable reels for most every conceivable application. This catalog describes and gives specifications on our most popular hose reels. If you don't see what you're looking for, give us a call and we will help you meet your needs.

Hannay Reels offers aluminum, carbon and stainless steel construction for most models.

Special coatings and finishes are also available.

Reel Type	I.D. Hose Sizes	Page
Hannay Reels Sales Policies		3
Hannay Reels Spec Worksheet		4
Hose Assemblies, Mounting Hole Sizes		5
Spring Rewind Hose Reels		
Series AG	1/4" – 1-1/2"	6-7
Series N400	1/4" or 3/8"	8
Series N500 (high pressure)*	1/4" or 3/8"	9
Series N600 (dual hose)	1/4" – 1/2"	10
Series 600 (dual hose)	1/4" – 3/4"	11
Series N700*	1/4" – 1/2"	12
Series 700*	1/4" – 1/2"	13
Series N800*	3/4" or 1"	14
Series 800*	3/4" or 1"	15
Series 900*	1-1/4" or 1-1/2"	16
Compact Manual Rewind Hose Reels		
Series 1000/MS-1000	1/4", 3/8" or 1/2"	17
Manual or Power Rewind Hose Reels		
Series 1500	3/8" – 5/8"	18
Series 1800	5/8" or 3/4"	19
Series 2000 (dual hose)	1/4" – 1/2"	20
Series G2000 (dual hose, manual only)	1/4" – 1/2"	21
Series 3000 (manual only)	3/4" or 1"	22
Series 3500 (manual only)	1-1/4" or 1-1/2"	23
Series 4000	3/4" or 1"	24
Series G4100	3/4" or 1"	25
Series 6000	1/2" – 1"	26-27
Series 7000 (dual hose)	3/4" or 1"	28
Series 7500*	1-1/4" or 1-1/2"	29
Series 8000	1-1/2" or 2"	30
Series 9000	2-1/2" or 3"	31
Portable Hose Reels on Wheels		
Series 1100, AT1200	3/8" – 1"	32
Portable Storage Reels on Wheels		
Series C1150, ATC1250	NA	33
Storage Reels: Manual or Power Rewind		
Series C1500	1/4" – 1" O.D.	34
Series C3200 (manual only)	1/2" – 1-1/2" O.D.	35
Chemical Reels: Manual or Power Rewind		
Series CHC	3/8" – 1-1/2" I.D.	36
Series SNC (Non-Corrosive)	3/8" – 5/8" I.D.	37
Vacuum Reels: Manual or Spring Rewind		
Series VAC4000	1-1/4" or 2" I.D.	38
Series VACN900, VAC900, VAC2900	1-1/4" or 2" I.D.	39

* Reel is appropriate for fuel/lubrication applications



Hannay Reels: The industry choice.

Designed to spec and built of the highest quality materials, our reels stand up to the most demanding conditions of any industry. We offer thousands of hose and cable reels that help improve efficiency, productivity, and safety in your operation by keeping hoses and cables organized and off the floor.

The heavy-duty design and construction of our reels ensure that they outlast the competition and save you money. And bolted-on components and conveniently located swivel joints make servicing our reels quick and trouble-free.

Every reel we build is created for the industry in which it will be used, from processing to welding to maintenance and more – never retrofitted to the job. That means you can trust Hannay reels to be durable and dependable for years to come.

Uses:

- Blasting/slurry
- Hydraulic/pneumatic power tools
- Washdown and sanitation
- Chemical transfer
- Power wash/steam cleaning
- Potable water
- Pressurized air
- Gas welding
- Fuel and lubrication
- Electric cable for lights, tools, and machinery
- In-plant firefighting
- Vacuum and suction

Hannay Reels **Sales Policies**

Hannay Reels 3-Year Limited Warranty

Products manufactured by Hannay Reels, Inc. ("Hannay") are warranted for 3 years from date of shipment when properly installed, maintained, and operated in accordance with Hannay instructions. In no event will Hannay have a warranty obligation for normal wear and tear, or for products that have, at Hannay's determination, been subjected to accident, abuse, misapplication, improper installation or improper maintenance. Common examples of normal wear and tear would include paint finish, swivel joint seal wear, and switch or motor brush wear.

Hannay makes no warranties, express or implied, other than those included in this warranty statement, and we disclaim any implied warrant of merchantability or fitness for any particular purpose. Hannay will not be liable for any consequential, incidental, or indirect damages from any cause whatsoever.

Failure to use a flexible inlet connection on any live hose reel will void the swivel joint warranty. Failure to use a properly sized circuit breaker with any electric rewind motor will void the electric motor warranty. Failure to use a filter and lubricator on any air rewind motor will void the air motor warranty. Failure to follow all procedures outlined in the Safety Guidelines document will void the warranty.

Components not manufactured by Hannay will be subject to the original manufacturers' warranties. Examples of such components include: hose and cable, motors, speed controls, and switches, swivel joints and seals, slip ring and brush assemblies.

Equipment which proves to be defective upon our inspection will be replaced free of charge, including freight to the customer. Our responsibility ceases upon delivery to any common carrier and we do not, unless previously instructed, insure shipments beyond point of delivery to such carrier. **No material will be accepted for return without a return goods authorization (RGA).** This warranty extends to the replacement or repair of the reel or part (no labor).

Hannay reserves the right to modify or alter materials, dimensions, design, and construction when necessary to improve the performance of the reel and/or accessories, or to meet delivery requirements.

Notice on Reel Finish

Standard finish on Hannay reels is a high performance enamel paint. Standard color is metallic graphite. Other colors available, please consult factory.

Most of the major components on standard reels are e-coated prior to receiving final topcoat paint finish. This combination of e-coat and enamel topcoat will meet the finish requirements of most customer applications and environments.

In cases where requirements cannot be met with the standard finish, Hannay Reels can coat any model reel with an automotive primer, allowing application of final coating at your facility.

Alternatively, Hannay Reels can provide a quote for matching a customer-provided paint specification. For further information, please contact your Hannay Reels sales engineer and a special paint request form will be sent to you.

For environments where no paint finish is suitable, we offer both aluminum and stainless steel (304 grade) construction on most reel models.

Return Goods Policy

All Hannay reels are built to order. These orders are typically placed into production within 1 business day of receipt. Once production begins, it may not be possible to cancel the order.

To prevent returns because the wrong reels or parts were ordered, please use the Hannay Reels Spec Worksheet (either online or from our Ordering & Accessory Guide) when specifying reels. Be sure to include any size, weight, pressure and/or material compatibility limitations for the application.

In the event that an item does need to be returned for credit, repair or replacement, prior approval must be obtained from Hannay Reels. Upon your request, we will send a Return Goods

Authorization (RGA) form. A signed copy of this form must accompany the material when returned to us, with the RGA number clearly showing on the outside of the box—a label is provided to you that you can print and attach. No product will be accepted for return or credit without an authorized RGA number.

All material must be returned prepaid, unless otherwise noted on our RGA. No return will be accepted that has been damaged due to improper return packaging, tampered with or altered from its original condition. Our restocking and handling fee is a minimum of 25% for standard catalog reels and parts. Custom reels specially built to customer specifications cannot be returned for any reason.

Hannay Reels **Spec Worksheet**

To specify Hannay reels, fill out this simple form and mail, fax or email it to your dealer.

Photocopy this page or download and print from hannay.com

1. Who is the reel for?				
Contact			Date / /	
Company		Position		
Street Address				
City		State	Zip	Country
Phone ()		Fax ()	Email	

2. What is the reel for?			
<input type="checkbox"/> HOSE (check one): <input type="radio"/> Storage only <input type="radio"/> Live Single hose <input type="radio"/> Live Dual hose			
Inside diameter:	Hose length:	Bend radius:	Flat hose dimensions:
Outside diameter:	Hose weight:	Coupling spacing:	
Type of product handled live application: (check one):			
<input type="radio"/> Liquid (specify):	<input type="radio"/> Temperature:	<input type="radio"/> Oxygen/Acetylene:	<input type="radio"/> Other (specify):
<input type="radio"/> Gases (specify):	<input type="radio"/> Pressure:	<input type="radio"/> Hydraulic fluid (specify):	
Fluid path type: (check one): <input type="radio"/> Steel (standard) <input type="radio"/> Aluminum <input type="radio"/> Stainless Steel <input type="radio"/> Other			
Reel inlet type: (check one): <input type="radio"/> Swivel joint 90° (standard) <input type="radio"/> Straight			
Reel outlet type (riser): Size:			
Thread (check one):	<input type="radio"/> National Pipe Thread (NPT)	<input type="radio"/> Joint Industry Committee (JIC)	<input type="radio"/> Other
	<input type="radio"/> National Standard Thread (NST)	<input type="radio"/> British Standard Pipe (BSP)	

Indicate your custom specifications

CABLE (check one): <input type="radio"/> Live* <input type="radio"/> Storage only		
*Number of conductors, or wire gauge, required:		
*Number of connectors:	Cable weight:	Cable length:
*Voltage:	Outside diameter:	
*Amperage (live application only):	Bend radius:	

Indicate your custom specifications

3. What features does the reel need? Check type of rewind:			
<input type="checkbox"/> MANUAL REWIND			
<input type="radio"/> Disc rewind (hand over hand)	<input type="radio"/> Gear-driven crank	<input type="radio"/> Direct crank (permanent or removable)	<input type="radio"/> Chain-driven crank
<input type="checkbox"/> POWER REWIND			
<input type="radio"/> Spring	<input type="radio"/> Air	<input type="radio"/> Electric (voltage):	<input type="radio"/> Hydraulic
Type of installation (check one): <input type="radio"/> Floor <input type="radio"/> Wall <input type="radio"/> Overhead <input type="radio"/> Vehicle			
Temperature Range:		Environment:	
Accessories (if any):		Hose/Cable Stop: <input type="radio"/> Yes <input type="radio"/> No	
Roller Assemblies:			
Finish: <input type="checkbox"/> Painted steel (standard) <input type="checkbox"/> Aluminum <input type="checkbox"/> Polished <input type="checkbox"/> Unpolished <input type="checkbox"/> Stainless steel <input type="checkbox"/> Polished <input type="checkbox"/> Unpolished			

4. Specifying Location of Components

Optional Location of Components:
Location of the inlet, outlet riser, and rewind mechanism can be varied to meet your requirements and **must be specified on your order**. Unless otherwise specified, most reels will be shipped as **Right Top Rewind** with the inlet, outlet riser, and rewind mechanism on the operator's right.

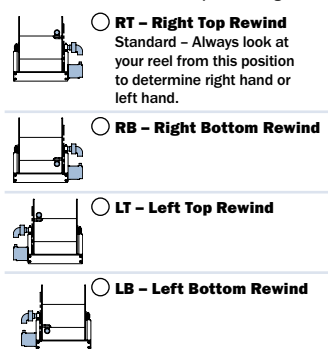

Note: Use component location initials as suffix after model number (ie: E1520-17-18 LT)

5. Please note size and/or weight limitations for your installation

SPECIFICATIONS

Depth: _____

Height: _____

Width: _____

Weight: _____

Check type of installation and roller position for spring reels:

<input type="radio"/> Drag Position SR	<input type="radio"/> Lift Position VR	<input type="radio"/> Wall Mount Position VR	<input type="radio"/> Wall Mount Position TR	<input type="radio"/> Drag Position TR
--	--	--	--	--

Constant tension available on all roller positions

Hose Assemblies

Complete Reel Packages are also available.

For further information, refer to the Reel Packages Sheet at Hannay.com.

Hose Assemblies

Allow us to quote the hose along with the reel to simplify your procurement process. Hannay inventories a wide variety of hose assemblies for common applications like general purpose air and water, petroleum products, hydraulics, oxygen/acetylene, breathing air, and rescue equipment. Special lengths, fittings, and custom application assemblies are usually available in 5 to 10 business days. Beside the I.D. and Length, be sure to know the Temperature Range, Fluid, Working Pressure, and Fitting Specifications for your hose.

Low Pressure Hose

We stock a variety of low pressure hose assemblies in several sizes and lengths. We offer hose with EPDM cover and tube and brass fittings, which are excellent for air, water, and many agricultural chemicals. EPDM is recommended for outside usage due to its resistance to heat, sunlight, and weathering.

For shop use, we offer a hose with high oil resistant tube and cover. It is suitable for use with petroleum based hydraulic fluid, lubricating oil, anti-freeze, diesel fuel, water, and air and may be special ordered in several different colors. Hoses for specialty applications are available upon request.

Medium and High Pressure Hose

Several different hydraulic and general purpose hose assemblies are offered to meet the specifications of your particular application. We stock an assortment of common sizes to be able meet your needs with a minimum delivery time.

Twin Hydraulic Hose

Hannay Reels offers bonded hydraulic hose that helps solve problems associated with unwinding and storing multiple lines. Various options are available not only for hydraulic fluid, but a wide variety of chemicals, agricultural sprays, urethane foam mixers, and fire resistant fluids.

Twin Oxygen/Acetylene Hose

We stock Grade R and Grade T twin hose assemblies in 1/4" and 3/8" in lengths of 50', 75', and 100' which will cover most requirements for oxygen/acetylene, as well as propane and MAPP. For oxygen/acetylene reels, see the Hannay Welding Reels Catalog H-0408-W.

Note: All spring rewind reels complete with hose are supplied with appropriate hose stop. (See Ordering & Accessory Guide.)

Mounting Hole Sizes

N Series Reels	7/16" wide x 7/8" long slot running front to back
Pressed Frame Reels and Channel Framed Reels	7/16" wide x 7/8" long slot running left to right
Series 1000	7/16" wide x 1 7/16" long slot
Series 1500, 1800, 2000, 4000	13/32" round holes

Series **AG** | With Air Speed Control Governor

To handle 1/4" through 1-1/2" I.D. hose.

Most Hannay spring reel models are available with an air governor rewind assist, which prevents the hose from winding back onto the reel too quickly. Speed is regulated by restricting air flow through an air governor attached to the rewind mechanism. The result is smooth, controlled rewind speed each and every time.

Unlike other speed control mechanisms designed for spring rewind reels, there are 3 major advantages to the Hannay design:

- 1. Highly scalable** – The air speed control governor can be scaled up to regulate speed on even the most powerful spring reels we offer. Other designs can only work on light-duty springs.
- 2. Operates in all climates** – Because the AG Series uses air flow to control speed (not hydraulic fluid, which can change viscosity depending on temperature), the reel's rewind speed is controlled and unaffected, even by cold weather.
- 3. Fully adjustable** – The end-user can turn the air restrictor clockwise or counterclockwise until the optimal rewind speed is found for the application.

For further information (other than dimensions) on any of the AG Series reels listed below, please go to the following pages in this catalog:

- AG600 Series: Go to page 11 (Series 600)
- AG700 Series: Go to page 13 (Series 700)
- AG800 Series: Go to page 15 (Series 800)
- AG900 Series: Go to page 16 (Series 900)



AG800 Series

Standard SR configuration shown

Model Number	Hose Capacity of Reel shown in feet/meter								Approx. Weight shown in lb/kg		Std. Roller Assy.	Reel Dimensions*** shown in inches/millimeter																			
	I.D. in.	1/4	3/8	1/2	3/4	1	1-1/4	1-1/2	NET	SHIP		A	B	C	D	E	F	G	H	X	Y										
	mm	6	10	13	19	25	32	38				mm	16	19	22	33	40	46	52	mm	16	19	22	33	40	46	52				
AG615-23-24-10.5B	2/65	2/60	2/30	-	-	-	-	-	117	152	AG303	9.25	3	10.5	25.25	22.75	16	23.88	12.5	4.5	20	235	76	267	641	578	406	607	318	114	508
AG617-25-26-15.5B	2/75	2/75	2/50	-	-	-	-	-	118	153	AG305	11.25	5	15.5	27	24.75	18	25.88	13.5	6.5	21.75	286	127	394	686	629	457	657	343	165	552
AG617-25-26-15.5A	2/100	2/85	-	-	-	-	-	-	145	180	AG305	11.25	5	15.5	27	24.75	18.75	25.88	13.5	6.5	21.75	286	127	394	686	629	476	657	343	165	552
AG618-30-31-15.5A	-	-	2/100	2/50	-	-	-	-	155	190	AG306	12.25	6	15.5	30.5	28.75	19.75	31.38	17	7.5	25.25	311	153	394	775	730	502	797	432	190	641
AG716-19-20-10.5J	-	50	50	-	-	-	-	-	101	136	AG304	10.25	4	10.5	20.5	18.75	14.75	20	10.62	5.5	14.75	260	102	267	521	22.75	375	508	270	139	375
AG716-23-24-15.5J	-	65	65	-	-	-	-	-	111	146	AG304	10.25	4	15.5	25.25	24.75	14.75	23.88	12.5	5.5	20	260	102	394	641	629	375	607	318	139	508
AG716-25-26-15.5B	-	75	75	-	-	-	-	-	115	150	AG304	10.25	4	15.5	27	24.75	14.75	25.88	13.5	5.5	21.75	260	102	394	686	629	375	657	343	139	552
AG718-25-26-15.5G	-	100	100	-	-	-	-	-	121	156	AG306	12.25	6	15.5	27	24.75	16.75	25.88	13.5	7.5	21.75	311	152	394	686	629	425	657	343	190	552
AG718-30-31-20D	-	150	125	-	-	-	-	-	152	187	AG306	12.25	6	20	30.5	28.75	16.75	31.38	17	7.5	25.25	311	152	508	775	730	425	797	432	190	641
AG818-23-24-10.5J	-	-	-	50	25	-	-	-	110	145	AG306	12.25	6	10.5	25.25	22.75	16.75	23.88	12.5	7.5	20	311	152	267	641	578	425	607	318	190	508
AG816-25-26-10.5B	-	-	-	60	35	-	-	-	121	156	AG304	10.25	4	10.5	27	24.75	14.75	25.88	13.5	5.5	21.75	260	102	267	686	629	375	657	343	140	552
AG818-25-26-10.5B	-	-	-	70	50	-	-	-	127	162	AG306	12.25	6	10.5	27	24.75	16.75	25.88	13.5	7.5	21.75	311	152	267	686	629	425	657	343	190	552
AG820-25-26-10.5A	-	-	-	85	75	-	-	-	156	191	AG308	14.25	8	10.5	27	24.75	19.5	25.88	13.5	9.5	21.75	362	204	267	686	629	495	657	434	241	552
AG820-30-31-10.5A	-	-	-	100	-	-	-	-	162	197	AG308	14.25	8	10.5	30.5	28.75	19.5	31.38	17	9.5	25.25	362	204	267	775	730	495	797	432	241	641
AG820-30-31-15.5A	-	-	-	100	-	-	-	-	170	205	AG308	14.25	8	15.5	30.5	28.75	19.5	31.38	17	9.5	25.25	362	204	394	775	730	495	797	432	241	641
AG920-25-26-10.5A	-	-	-	-	-	50	40	152	187	AG308	14.25	8	10.5	27	24.75	24	25.88	13.5	9.5	21.75	362	204	267	686	629	610	657	343	241	552	
AG922-30-31-10.5A	-	-	-	-	-	75	50	181	216	AG310	16.25	10	10.5	30.5	28.75	26	31.38	17	11.5	25.25	413	254	267	775	730	660	797	432	292	641	

Notes:

A hose stop is necessary to keep spring from unwinding.

- Specifications subject to change.
- Reel models and capacities shown are for standard drag applications; for vertical lift applications, consult factory.

3. Other sizes, from standard components, available on request.

4. **Finish:** Refer to page 3.

5. **Be sure to check dimensions and weights prior to ordering.**

NOTICE: A flexible connector must be used between the inlet pipe and the inlet swivel joint.

*** X, Y indicate mounting holes. See page 5.

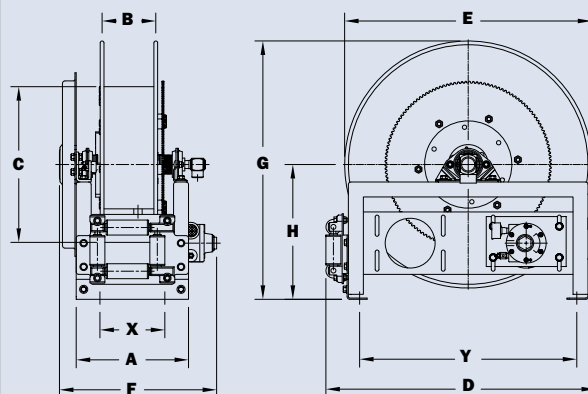

AG800 shown

Available Roller Positions



SR (STD)



VR (OPT)



TR (OPT)



TR (Wallmount)

Series N400

• Gas Welding

To handle twin 1/4" or 3/8" I.D. welding hose.

- Heavy-duty spring motor.
- Non-sparking ratchet assembly.
- Declutching arbor to prevent damage from reverse winding.
- Standard inlets: 90° ball bearing swivel joints, 1/2" female NPT threads.
- Standard outlets: male 9/16"-18 threads, right-hand for oxygen, left-hand for gas.
- Pressures to 300 psi (21 bar).
- Standard fluid temperatures from -40° F to +250 °F (-40° C to +121° C). Optional temperature ratings available - consult factory.
- Type of gas used **MUST** be specified.
- Hose stop is required.
- 4-way roller assembly. SR position is standard, other configurations available, must specify.



Standard SR configuration shown

PARTS DRAWING – ISO 186

Model Number	Hose Capacity of Reel shown in feet/meter			Approx. Weight shown in lb/kg		Standard Roller Assy.	Reel Dimensions*** shown in inches/millimeter							
	I.D. in.	1/4	3/8	NET	SHIP		A	B	C	E	F	G	H	X
	mm	6	9											
N416-17-18-8L		2/50	-	64	69*	N204	10	4	8	19.5	15	17.38	9.13	8
		2/15	-	29	31		254	102	203	495	381	441	232	203
N416-19-20-8L		-	2/50	68	74*	N204	10	4	8	20.75	15	20	10.62	8
		-	2/15	31	34		254	102	203	527	381	508	270	203
N416-19-20-10.5C		2/25	2/25	70	77*	N204	10	4	10.5	20.75	15	20	10.62	8
		2/8	2/8	32	35		254	102	267	527	381	508	270	203
N416-19-20-8J		2/50	2/50	74	804*	N204	10	4	8	20.75	15	20	10.62	8
		2/15	2/15	34	36		254	102	203	527	381	508	270	203
N417-23-24-10.5G		2/75	2/75	94	115	N205	11	5	10.5	24	16	24	12.62	9
		2/23	2/23	43	52		279	127	267	610	406	610	320	229
N417-25-26-10.5G		2/100	2/100	97	132	N205	11	5	10.5	25.5	16	26	13.62	9
		2/30	2/30	43	52		279	127	267	648	406	660	346	229

Notes:

A hose stop is necessary to keep spring from unwinding.

1. Specifications subject to change.
2. Reel models and capacities shown are for standard drag applications; for vertical lift applications, consult factory.
3. Other sizes, from standard components, available on request.
4. **Finish:** Refer to page 3.

5. **Be sure to check dimensions and weights prior to ordering.**

NOTICE: A flexible connector must be used between the inlet pipe and the inlet swivel joint.

* When shipped as a parcel package (via FedEx or UPS Ground), joints loose. Net weight plus carton weight.

*** X, Y indicate mounting holes. See page 5.

Available Roller Positions

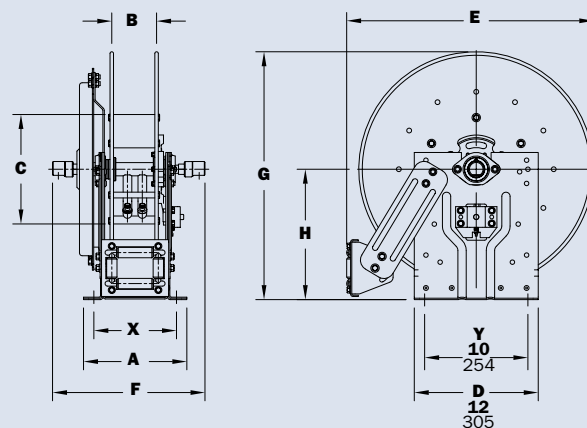
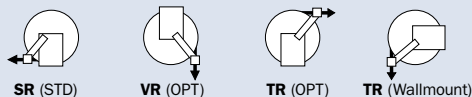

High Pressure | Series N500

• Chassis Grease • Hydraulics • Air/Water

To handle single 1/4" or 3/8" I.D. hose.

- Compact frame and narrow base.
- Non-sparking ratchet assembly.
- Declutching arbor to prevent damage from reverse winding.
- Standard inlet: 90° swivel joint, 1/4" female NPT threads. 3/8" female NPT threads are optional and **must be specified**.
- Standard outlet: 1/4" female NPT threads. 3/8" female NPT threads are optional and **must be specified**.
- Other threads can be furnished and **must be specified**.
- Standard 1/4" pressure 10,000 psi (690 bar); Standard 3/8" pressure: 3000 psi (207 bar). Optional 3/8" pressure: 8000 psi (552 bar) – must specify.
- Standard fluid temperatures from -40° F to +250 °F (-40° C to +121° C). Optional temperature ratings available - consult factory.
- 4-way roller assembly. SR and VR roller positions: swivel joint is standard on the right. TR roller positions: swivel joint is standard on the left. Other configurations available, must specify.
- Constant tension is available – consult factory.



Standard SR configuration shown with optional full-flow swivel joint



Optional Swivel Mounting Bracket

Part No. 9908.9990.

For N-Series spring retractable reels, available as a kit. Conditions apply, consult factory.

PARTS DRAWING – ISO 92

Model Number	Hose Capacity of Reel shown in feet/meter			Approx. Weight shown in lb/kg			Standard Roller Assy.	Reel Dimensions*** shown in inches/millimeter							
	I.D. in. mm	1/4 6	3/8 10	NET	UPS/FedEx SHIP Wt.	Freight SHIP Wt.		A	B	C	E	F	G	H	X
	O.D. in. mm	5/8 16	3/4 19					9	3	8	18.12	10.38	16.12	9.12	7
N515-14-16-8L	25 8	25 8	48 22	64* 29	83 38	N203	9 229	3 76	8 203	18.12 460	10.38 264	16.12 409	9.12 232	7 178	
N515-16-17-10.5C	35 11	35 11	51 23	67* 30	86 39	N203	9 229	3 76	10.5 267	19 483	10.38 264	17 432	9.12 232	7 178	
N515-19-20-10.5J	50 15	50 15	63 29	81* 37	98 44	N203	9 229	3 76	10.5 267	20.75 527	10.38 264	20 508	10.62 270	7 178	
N515-23-24-15.5J	75 23	65 20	75 34	92* 42	110 50	N203	9 229	3 76	15.5 394	24 610	10.38 264	24 610	12.62 321	7 178	
N516-25-26-15.5B	75 23	75 23	90 34	-- --	125 57	N204	10 254	4 102	15.5 394	25.5 648	11.38 289	26 660	13.62 346	8 203	

Notes:

A hose stop is necessary to keep spring from unwinding.

1. Specifications subject to change.
2. Reel models and capacities shown are for standard drag applications; for vertical lift applications, consult factory.
3. Other sizes, from standard components, available on request.
4. **Finish:** Refer to page 3.

5. Be sure to check dimensions and weights prior to ordering.

NOTICE: A flexible connector must be used between the inlet pipe and the inlet swivel joint.

* Dimensional weight may apply when shipped as a parcel package (via FedEx or UPS Ground).

*** X, Y indicate mounting holes. See page 5.

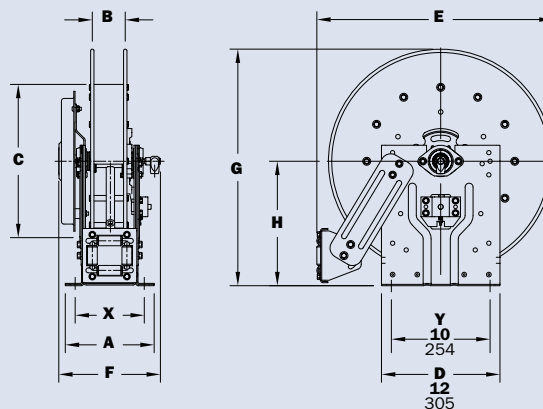

Available Roller Positions



SR (STD)



VR (OPT)



TR (OPT)



TR (Wallmount)

Series N600 | Dual Hose

• Hydraulics • Spray Painting • Air/Water

To handle dual 1/4" through 1/2" I.D. hose.

- Narrow frame and compact mounting base.
- Non-sparking ratchet assembly.
- Declutching arbor to prevent damage from reverse winding.
- Standard inlets: 90° full-flow swivel joints with Viton® seals, 1/2" female NPT threads.
- Optional balanced pressure (BP) swivel joints are available upon request. Subtract 1-3/4" from "F" dimension.
- Standard outlets: 1/2" female NPT threads.
- Standard pressures to 3000 psi (207 bar), available up to 10,000 psi (690 bar) – must specify.
- Standard fluid temperatures from -40° F to +250 °F (-40° C to +121° C). Optional temperature ratings available - consult factory.
- 4-way roller assembly. SR position is standard, other configurations available, must specify.
- Constant tension is available – consult factory.
- Reels for use with oxygen/acetylene. See Series N400 on page 8.



Standard SR configuration shown

PARTS DRAWING – ISO 80

Model Number	Hose Capacity of Reel shown in feet / meter				Approx. Weight shown in lb/kg			Standard Roller Assy.	Reel Dimensions*** shown in inches/millimeter								
	I.D. in. mm	1/4 6	3/8 10	1/2 13	NET	UPS/FedEx SHIP Wt.	Freight SHIP Wt.		A	B	C	E	F Full-Flow	F BP	G	H	X
	O.D. in. mm	5/8 16	3/4 19	7/8 22													
N615-19-20-10.5C	2/35	2/35	2/20	63	74*	98	N203	9	3	10.5	20.75	14	12.25	20	10.62	7	
	2/11	2/11	2/6	29	34	44		229	76	267	527	356	311	508	270	178	
N617-19-20-10.5J	2/50	2/50	2/25	66	84*	101	N205	11	5	10.5	20.75	16	14.25	20	10.62	9	
	2/15	2/15	2/8	30	38	46		279	127	267	527	406	362	508	270	229	
N615-23-24-10.5B	2/65	2/60	2/30	87	-	122	N203	9	3	10.5	24	14	12.25	24	12.62	7	
	2/20	2/18	2/9	40	-	55		229	76	267	610	356	311	610	321	178	
N617-25-26-15.5B	2/75	2/75	2/50	93	-	128	N205	11	5	15.5	25.5	16	14.25	26	13.62	9	
	2/23	2/23	2/15	42	-	58		279	127	394	648	406	362	660	346	229	
N617-25-26-15.5A	2/100	2/85	-	120	-	155	N205	11	5	15.5	25.5	16.75	15	26	13.62	9	
	2/31	2/26	-	54	-	70		279	127	394	648	425	381	660	346	229	

Notes:

A hose stop is necessary to keep spring from unwinding.

1. Specifications subject to change.
2. Reel models and capacities shown are for standard drag applications; for vertical lift applications, consult factory.
3. Other sizes, from standard components, available on request.
4. Finish: Refer to page 3.

5. Be sure to check dimensions and weights prior to ordering.

NOTICE: A flexible connector must be used between the inlet pipe and the inlet swivel joint.

*Dimensional weight may apply when shipped as a parcel package (via FedEx or UPS Ground).

*** X, Y indicate mounting holes. See page 5.

For hydraulic tool circuit applications, full flow swivels with Viton® seals are recommended.

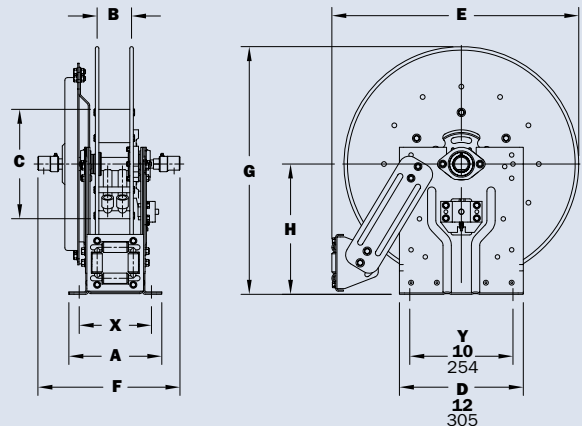

Available Roller Positions

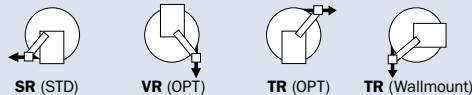

Dual Hose | **Series 600**

• Hydraulics • Spray Painting • Air/Water

To handle dual 1/4" through 3/4" I.D. hose.

- Rollformed channel frame for heavy-duty applications.
- Non-sparking ratchet assembly.
- Declutching arbor to prevent damage from reverse winding.
- Standard inlets: 90° full-flow swivel joints with Viton® seals, 1/2" female NPT threads (1" inlet available). Must be specified.
- Optional balanced pressure (BP) swivel joints are available upon request. Subtract 1-3/4" from "F" dimension.
- Standard outlets: 1/2" female NPT threads (3/4" outlet available). Must be specified.
- Standard pressures to 3000 psi (207 bar), available up to 10,000 psi (690 bar) – must specify.
- Standard fluid temperatures from -40° F to +250° F (-40° C to +121° C). Optional temperature ratings available - consult factory.
- 4-way roller assembly. SR position is standard, other configurations available, must specify.
- Constant tension is available – consult factory.
- Reels for use with oxygen/acetylene. See Series N400 on page 8.



Standard SR configuration shown

PARTS DRAWING – ISO 8

Model Number	Hose Capacity of Reel shown in feet/meter					Approx. Weight shown in lb/kg		Standard Roller Assy.	Reel Dimensions*** shown in inches/millimeter										
	I.D. in.	1/4	3/8	1/2	3/4	NET	SHIP		A	B	C	D	E	F	F	G	H	X	Y
	mm	6	10	13	19				Full-Flow	BP									
615-23-24-10.5B	2/65	2/60	2/30	-	-	70	105	R203	8.25	3	10.5	24.62	22.75	15	13.38	23.88	12.5	3.5	20
	2/20	2/18	2/9	-	-	32	48		210	76	267	625	578	381	340	607	318	89	508
617-25-26-15.5B	2/75	2/75	2/50	-	-	93	128	R205	10.25	5	15.5	26.38	24.75	17	15.38	25.88	13.5	5.5	21.75
	2/23	2/23	2/15	-	-	42	58		260	127	394	670	629	432	391	657	343	140	552
617-25-26-15.5A	2/100	2/85	-	-	-	120	155	R205	10.25	5	15.5	26.38	24.75	17.75	16.06	25.88	13.5	5.5	21.75
	2/31	2/26	-	-	-	54	70		260	127	394	670	629	451	408	657	343	140	552
†618-30-31-15.5A	-	-	2/100	2/50	-	130	165	R206	11.25	6	15.5	29.88	28.75	18.75	17.06	31.38	17	6.5	25.25
	-	-	2/31	2/15	-	59	75		286	152	394	759	730	476	433	797	432	165	641

Notes:

A hose stop is necessary to keep spring from unwinding.

1. Specifications subject to change.
2. Reel models and capacities shown are for standard drag applications; for vertical lift applications, consult factory.
3. Other sizes, from standard components, available on request.
4. Finish: Refer to page 3.

5. Be sure to check dimensions and weights prior to ordering.

NOTICE: A flexible connector must be used between the inlet pipe and the inlet swivel joint.

***X, Y indicate mounting holes. See page 5.

† Must specify if 1" joints and 3/4" outlet risers are required.

For hydraulic tool circuit applications, full flow swivels with Viton® seals are recommended.

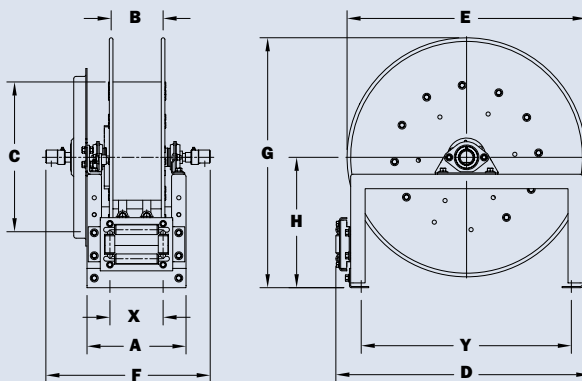

Available Roller Positions

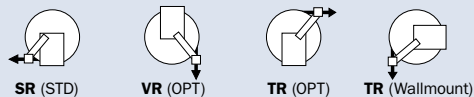

Series N700

- Lubrication • Air/Water • Assembly Operations
- Washdown • Air Tools • General Industrial Applications

To handle 1/4" through 1/2" I.D. hose.

- Narrow frame and compact mounting base.
- Non-sparking ratchet assembly.
- Declutching arbor to prevent damage from reverse winding.
- Standard inlet: 90° balanced pressure swivel joint, 1/2" female NPT threads.
- Standard outlet: 1/2" female NPT threads.
- Standard pressures to 3000 psi (207 bar), available up to 10,000 psi (690 bar) – must specify.
- Standard fluid temperatures from -40° F to +250 °F (-40° C to +121° C). Optional temperature ratings available - consult factory.
- 4-way roller assembly. SR and VR roller positions: swivel joint is standard on the right. TR roller positions: swivel joint is standard on the left. Other configurations available, must specify.
- Constant tension is available – consult factory.



Standard SR configuration shown



Optional Swivel Mounting Bracket

Part No. 9908,9990. For N-Series spring retractable reels, available as a kit. Conditions apply, consult factory.

PARTS DRAWING – ISO 79

Model Number	Hose Capacity of Reel shown in feet / meter				Approx. Weight shown in lb/kg			Standard Roller Assy.	Reel Dimensions*** shown in inches/millimeter							
	I.D. in. mm	1/4 6	3/8 10	1/2 13	NET	UPS/FedEx SHIP Wt.	Freight SHIP Wt.		A	B	C	E	F	G	H	X
	O.D. in. mm	5/8 16	3/4 19	7/8 22												
N716-14-16-8C	-	25	25	52	64*	87	N204	10	4	8	18.12	11.63	16.12	9.12	8	
	-	8	8	24	29	39		254	102	203	460	295	409	232	203	
N716-16-17-10.5C	-	35	35	55	69*	90	N204	10	4	10.5	19	11.63	17	9.12	8	
	-	11	11	25	31	41		254	102	267	483	295	432	232	203	
†N716-17-18-8L	-	50†	50†	55	68*	90	N204	10	4	8	19.5	11.63	17.38	9.12	8	
	-	15†	15†	25	31	41		254	102	203	495	295	441	232	203	
N716-19-20-10.5J	-	50	50	64	82*	99	N204	10	4	10.5	20.75	11.63	20	10.62	8	
	-	15	15	29	37	45		254	102	267	527	295	508	270	203	
N716-23-24-15.5J	-	65	65	79	94*	114	N204	10	4	15.5	24	11.63	24	12.62	8	
	-	20	20	36	43	52		254	102	394	610	295	610	321	203	
N716-23-24-15.5G	100	75	65	94	-	129	N204	10	4	15.5	24	11.63	24	12.62	8	
	30	23	20	43	-	59		254	102	394	610	295	610	321	203	
N716-25-26-15.5B	-	75	75	90	-	125	N204	10	4	15.5	25.5	11.63	26	13.62	8	
	-	23	23	41	-	57		254	102	394	648	295	660	346	203	
N718-25-26-15.5G	-	100	100	96	-	131	N206	12	6	15.5	25.5	13.63	26	13.62	10	
	-	30	30	44	-	59		305	152	394	648	346	660	346	254	
††N718-25-26-15.5 SD	-	100	100	104	-	139	N206	12	6	15.5	25.5	14.38	26	13.62	10	
	-	30	30	47	-	63		305	152	394	648	365	660	345	254	

Notes:

A hose stop is necessary to keep spring from unwinding.

1. Specifications subject to change.
2. Reel models and capacities shown are for standard drag applications; for heavy-duty or vertical lift applications, consult factory.
3. Other sizes, from standard components, available on request.
4. **Finish:** Refer to page 3.
5. **Be sure to check dimensions and weights prior to ordering.**

NOTICE: A flexible connector must be used between the inlet pipe and the inlet swivel joint.

- *Dimensional weight may apply when shipped as a parcel package (via FedEx or UPS Ground).
- ***X, Y indicate mounting holes. See page 5.
- †Capacity based on low pressure air hose only. Not for vertical lift applications.
- ††SD spring to be used for heavy-duty or vertical lift applications, consult factory.

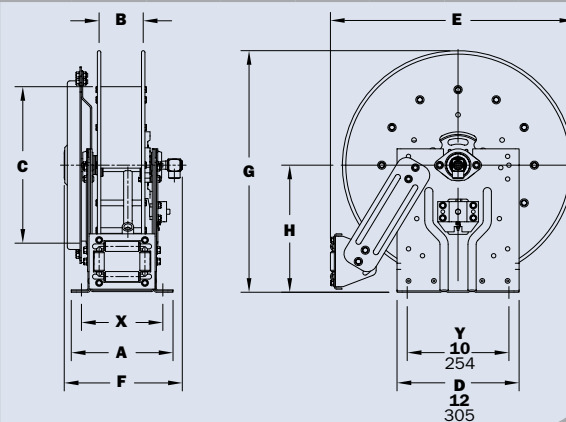

Available Roller Positions

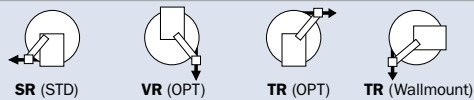

Series 700

- Lubrication • Air/Water • Assembly Operations
- Washdown • Air Tools • General Industrial Applications

To handle 1/4" through 1/2" I.D. hose.

- Rollformed channel frame for heavy-duty applications.
- Non-sparking ratchet assembly.
- Declutching arbor to prevent damage from reverse winding.
- Standard inlet: 90° balanced pressure swivel joint, 1/2" female NPT threads.
- Standard outlet: 1/2" female NPT threads.
- Standard pressures to 3000 psi (207 bar), available up to 10,000 psi (690 bar) – must specify.
- Standard fluid temperatures from -40° F to +250 °F (-40° C to +121° C). Optional temperature ratings available - consult factory.
- 4-way roller assembly. SR and VR roller positions: swivel joint is standard on the right. TR roller positions: swivel joint is standard on the left. Other configurations available, must specify.
- Constant tension is available – consult factory.



Standard SR configuration shown

PARTS DRAWING – ISO 66

Model Number	Hose Capacity of Reel shown in feet /meter				Approx. Weight shown in lb/kg			Standard Roller Assy.	Reel Dimensions*** shown in inches/millimeter									
	I.D. in.	1/4	3/8	1/2	NET	UPS/ FedEx SHIP Wt.	Freight SHIP Wt.		A	B	C	D	E	F	G	H	X	Y
	mm	6	10	13					mm	5/8	3/4	7/8	mm	16	19	22		
716-23-24-15.5J	-	65	65	79	92*	114	R204	9.25	4	15.5	24.5	22.75	12.62	23.88	12.5	4.5	20	
	-	20	20	36	42	52		235	102	394	622	578	321	607	318	114	508	
716-23-24-15.5G	100	75	65	94	-	129	R204	9.25	4	15.5	24.5	22.75	12.62	23.88	12.5	4.5	20	
	30	23	20	43	-	59		235	102	394	622	578	321	607	318	114	508	
716-25-26-15.5B	-	75	75	90	-	125	R204	9.25	4	15.5	26.25	24.75	12.62	25.88	13.5	4.5	21.75	
	-	23	23	41	-	57		235	102	394	667	629	321	657	343	114	552	
718-25-26-15.5G	-	100	100	96	-	131	R206	11.25	6	15.5	26.25	24.75	14.62	25.88	13.5	6.5	21.75	
	-	30	30	44	-	59		286	152	394	667	629	371	657	343	165	552	
†718-25-26-15.5 SD	-	100	100	98	-	133	R206	11.25	6	15.5	26.25	24.75	15.38	25.88	13.5	6.5	21.75	
	-	30	30	44	-	60		286	152	394	667	629	391	657	343	165	552	
718-30-31-20D	-	150	125	127	-	162	R206	11.25	6	20	30.5	28.75	15.38	31.38	17	6.5	25.25	
	-	46	38	58	-	73		286	152	508	775	730	391	797	432	165	641	

Notes:

A hose stop is necessary to keep spring from unwinding.

1. Specifications subject to change.
2. Reel models and capacities shown are for standard drag applications; for heavy-duty or vertical lift applications, consult factory.
3. Other sizes, from standard components, available on request.
4. Finish: Refer to page 3.

5. Be sure to check dimensions and weights prior to ordering.

NOTICE: A flexible connector must be used between the inlet pipe and the inlet swivel joint.
 *Dimensional weight may apply when shipped as a parcel package (via FedEx or UPS Ground).
 *** X, Y indicate mounting holes. See page 5.
 †SD spring to be used for heavy-duty or vertical lift applications, consult factory.

Available Roller Positions

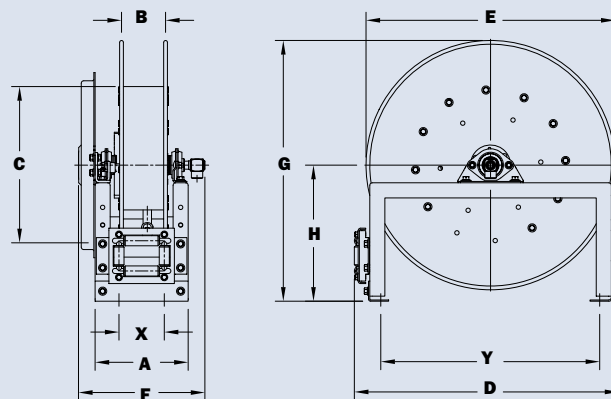
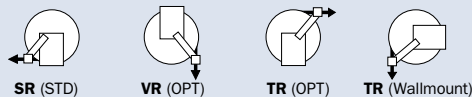

Series N800

- Fuel Dispensing (Consult Factory)
- Waste Oil Evacuation • Air/Water

To handle 3/4" or 1" I.D. hose.

- Narrow frame and compact mounting base.
- Non-sparking ratchet assembly.
- Declutching arbor to prevent damage from reverse winding.
- Standard inlet: 90° balanced pressure swivel joint, 1" female NPT threads.
- Standard outlet: 1" female NPT threads.
- Standard pressures to 2000 psi (138 bar), available up to 6000 psi (414 bar) – must specify.
- Standard fluid temperatures from -40° F to +250 °F (-40° C to +121° C). Optional temperature ratings available - consult factory.
- 4-way roller assembly. SR and VR roller positions: swivel joint is standard on the right. TR roller positions: swivel joint is standard on the left. Other configurations available, must specify.
- Constant tension is available – consult factory.



Optional TR configuration shown

PARTS DRAWING – ISO 81

Model Number	Hose Capacity of Reel shown in feet / meter			Approx. Weight shown in lb/kg			Standard Roller Assy.	Reel Dimensions*** shown in inches/millimeter							
	I.D. in.	3/4	1	NET	UPS/FedEx SHIP Wt.	Freight SHIP Wt.		A	B	C	E	F	G	H	X
	mm	19	25												
N816-19-20-10.5J	25	15	75	75	83*	110	N204	10	4	10.5	20.75	13	20	10.62	8
	8	5	34	34	38	50		254	102	267	527	330	508	270	203
†N818-23-24-10.5J	50†	25†	87	87	-	122	N206	12	6	10.5	24	15	24	12.62	10
	15†	8†	39	39	-	55		305	152	267	610	381	610	321	254
N816-25-26-10.5B	50	35	96	96	-	131	N204	10	4	10.5	25.5	13	26	13.62	8
	15	11	44	44	-	59		254	102	267	648	330	660	346	203
N818-25-26-10.5B	-	50	102	102	-	137	N206	12	6	10.5	25.5	15	26	13.62	10
	-	15	46	46	-	62		305	152	267	648	381	660	346	254
†N818-25-26-10.5G	75	-	108	108	-	143	N206	12	6	10.5	25.5	15	26	13.62	10
	23	-	49	49	-	65		305	152	267	648	381	660	346	254
N818-25-26-10.5 SD	75	-	110	110	-	145	N206	12	6	10.5	25.5	15.75	26	13.62	10
	23	-	46	46	-	66		305	152	267	648	381	660	346	254

Notes:

A hose stop is necessary to keep spring from unwinding.

1. Specifications subject to change.
2. Reel models and capacities shown are for standard drag applications; for vertical lift applications, consult factory.
3. Other sizes, from standard components, available on request.
4. **Finish:** Refer to page 3.

5. Be sure to check dimensions and weights prior to ordering.

NOTICE: A flexible connector must be used between the inlet pipe and the inlet swivel joint.

*Dimensional weight may apply when shipped as a parcel package (via FedEx or UPS Ground).

*** X, Y indicate mounting holes. See page 5.

†Capacity based on low pressure air hose only.

Available Roller Positions



SR (STD)



VR (OPT)



TR (OPT)



TR (Wallmount)

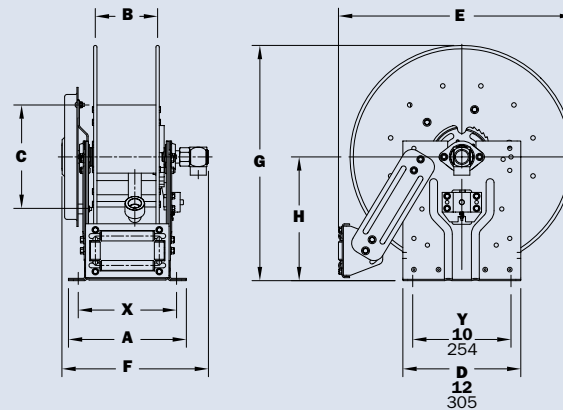

Series 800

- Fuel Dispensing (Consult Factory)
- Waste Oil Evacuation • Air/Water

To handle 3/4" or 1" I.D. hose.

- Rollformed channel frame for heavy-duty applications.
- Non-sparking ratchet assembly.
- Declutching arbor to prevent damage from reverse winding.
- Standard inlet: 90° balanced pressure swivel joint, 1" female NPT threads.
- Standard outlet: 1" female NPT threads.
- Standard pressures to 2000 psi (138 bar), available up to 6000 psi (414 bar) – must specify.
- Standard fluid temperatures from -40° F to +250 °F (-40° C to +121° C). Optional temperature ratings available - consult factory.
- 4-way roller assembly. SR and VR roller positions: swivel joint is standard on the right. TR roller positions: swivel joint is standard on the left. Other configurations available, must specify.
- Constant tension is available – consult factory.



Standard SR configuration shown

PARTS DRAWING – ISO 42

Model Number	Hose Capacity of Reel shown in feet /meter			Approx. Weight shown in lb/kg		Standard Roller Assy.	Reel Dimensions*** shown in inches/millimeter									
	I.D. in. mm	3/4 19	1 25	NET	SHIP		A	B	C	D	E	F	G	H	X	Y
	O.D. in. mm	1-9/32 33	1-1/2 38													
†818-23-24-10.5J		50†	25†	87	122	R206	11.25	6	10.5	24.5	22.75	15.62	23.88	12.5	6.5	20
		15†	8†	39	55		286	152	267	622	578	397	607	318	165	508
816-25-26-10.5B		50	35	96	131	R204	9.25	4	10.5	26.25	24.75	13.62	25.88	13.5	4.5	21.75
		15	11	44	59		235	102	267	667	629	346	657	343	114	552
818-25-26-10.5B		-	50	102	137	R206	11.25	6	10.5	26.25	24.75	15.62	25.88	13.5	6.5	21.75
		-	15	46	62		286	152	267	667	629	397	657	343	165	552
818-25-26-10.5 SD		75	-	110	145	R206	11.25	6	10.5	26.25	24.75	16.38	25.88	13.5	6.5	21.75
		23	-	46	66		286	152	267	667	629	416	657	343	165	552
820-25-26-10.5A		-	75	131	166	R308	13.25	8	10.5	27	24.75	18.38	25.88	13.5	8.5	21.75
		-	23	59	75		337	203	267	686	629	467	657	343	216	552
820-30-31-10.5A		-	100	137	172	R308	13.25	8	10.5	30.5	28.75	18.38	31.38	17	8.5	25.25
		-	30	62	78		337	203	267	775	730	467	797	432	216	641
820-30-31-15.5A		100	-	145	180	R308	13.25	8	15.5	30.5	28.75	18.38	31.38	17	8.5	25.25
		30	-	66	82		337	203	394	775	730	467	797	432	216	641

Notes:

A hose stop is necessary to keep spring from unwinding.

1. Specifications subject to change.
2. Reel models and capacities shown are for standard drag applications; for vertical lift applications, consult factory.
3. Other sizes, from standard components, available on request.
4. Finish: Refer to page 3.

5. Be sure to check dimensions and weights prior to ordering.

NOTICE: A flexible connector must be used between the inlet pipe and the inlet swivel joint.
 *** X, Y indicate mounting holes. See page 5.
 †Capacity based on low pressure air hose only.

Available Roller Positions

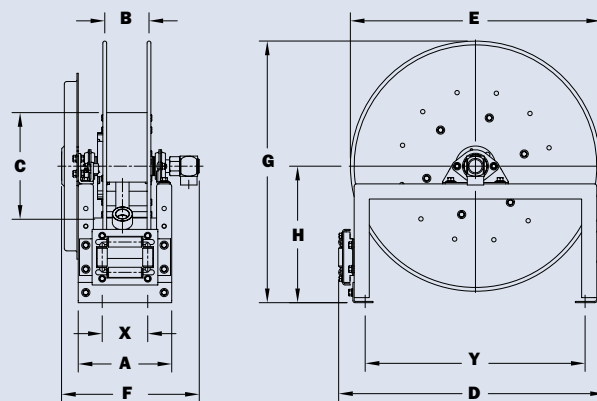
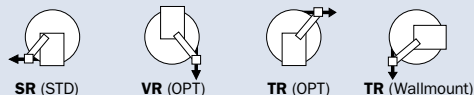

Series 900

- **Bulk Transfer • Fuel Dispensing** (Consult Factory)
- **Suction/Discharge** (Consult Factory)

To handle 1-1/4" or 1-1/2" I.D. hose.

- Rollformed channel frame construction.
- Non-sparking ratchet assembly.
- Declutching arbor to prevent damage from reverse winding.
- Standard inlet: 90° swivel joint, 1-1/2" female NPT threads, and 2" Victaulic® groove.
- Standard outlet: 1-1/2" female NPT threads.
- Standard pressures to 1000 psi (41 bar).
- Standard fluid temperatures from -20° F to +212 °F (-29° C to +100° C). Optional temperature ratings available - consult factory.
- 4-way roller assembly. SR and VR roller positions: swivel joint is standard on the right. TR roller positions: swivel joint is standard on the left. Other configurations available, must specify.
- Constant tension is available – consult factory.



Standard SR configuration shown

PARTS DRAWING – ISO 29

Model Number	Hose Capacity of Reel shown in feet / meter			Approx. Weight shown in lb/kg		Standard Roller Assy.	Reel Dimensions*** shown in inches/millimeter								
	I.D. in.	1-1/4	1-1/2	NET	SHIP		A	B	D	E	F	G	H	X	Y
	mm	32	38				mm	1-13/16	2-1/16	mm	46	52	mm	10.5	267
922-23-24-10.5B	40	25	104	139	R310	15.25	10	25.25	22.75	24	23.88	12.5	10.5	20	
	12	8	47	63		387	254	641	22.75	610	607	318	267	508	
920-25-26-10.5A	50	40	127	162	R308	13.25	8	27	24.75	22.75	25.88	13.5	8.5	21.75	
	15	12	58	73		337	203	686	629	578	657	343	216	552	
922-30-31-10.5A	75	50	156	191	R310	15.25	10	30.5	28.75	24.75	31.38	17	10.5	25.25	
	23	15	71	87		387	254	775	730	629	797	432	267	641	

Notes:

A hose stop is necessary to keep spring from unwinding.

1. Specifications subject to change.
2. Reel models and capacities shown are for standard drag applications; for vertical lift applications, consult factory.
3. Other sizes, from standard components, available on request.
4. **Finish:** Refer to page 3.

5. Be sure to check dimensions and weights prior to ordering.

NOTICE: A flexible connector must be used between the inlet pipe and the inlet swivel joint.

*** X, Y indicate mounting holes. See page 5.

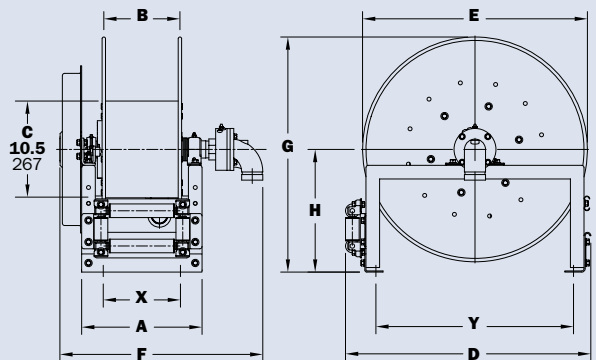

Available Roller Positions

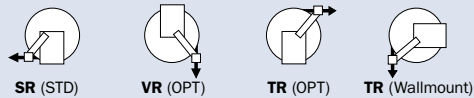

Series 1000

- Pressure Washing • Washdown
- Spray Operations • Air

To handle single 1/4", 3/8" or 1/2" I.D. hose.

- Lightweight, compact with an e-coated frame.
- Direct crank rewind permanently attached.
- Adjustable cam-lock brake standard.
- Exterior mounting holes for easier installation.
- Redesigned (and field installable) pin lock.
- Standard inlet: 90° ball bearing swivel joint, 1/2" female NPT threads.
- Standard outlet: 3/8" female NPT threads, 1/2" available upon request.
- Standard pressures to 3000 psi (207 bar), available up to 5,000 psi (345 bar) – must specify.
- Standard fluid temperatures from +32° F to +400 °F (0° C to +204° C). Optional temperature ratings available - consult factory.



1000 Series
Standard configuration shown in graphite finish with optional pin lock

MS-1000 Series

- Base mounting holes are inside frame for smaller footprint - see diagram to the right for specific dimensions.
- Shorter knob handle standard on MS-1000 for space saving.

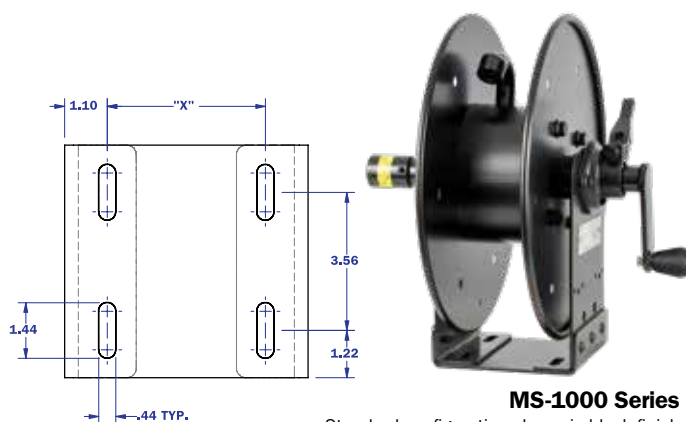

MS-1000 Series
Standard configuration shown in black finish

PARTS DRAWING – 1000/MS-1000–ISO 165

Model Number	Hose Capacity of Reel shown in feet /meter				Approx. Weight Crank Rewind shown in lb/kg			Reel Dimensions*** shown in inches/millimeter			
	I.D. in.	1/4	3/8	1/2	NET	UPS / FedEx SHIP Wt.	Freight SHIP Wt.	A	B	F	X
	mm	6	10	13							
1014-14-16		100	75	40	23	42*	58	11.5	6	18.75	10
		31	23	12	10	19	26	292	152	476	254
1016-14-16		150	100	70	24	42*	59	13.5	8	20.75	12
		46	31	21	11	19	27	343	203	527	305
1020-14-16		250	175	100	25	42*	60	17.5	12	24.75	16
		76	53	30	11	19	27	445	305	629	406
MS-1012-14-16	-	50	-	22	42*	57	6.5	4	14.50	4.06	
	-	15	-	10	19	26	165	101	368	103	
MS-1014-14-16	-	75	-	23	42*	58	8.5	6	16.50	6.06	
	-	23	-	11	19	27	216	152	419	154	

Notes:

1. Specifications subject to change.
2. Other sizes, from standard components, available on request.
3. **Finish:** Refer to page 3.
4. **Be sure to check dimensions and weights prior to ordering.**

NOTICE: A flexible connector must be used between the inlet pipe and the inlet swivel joint.

* Dimensional weight may apply when shipped as a parcel package (via FedEx or UPS Ground).

*** X, Y indicate mounting holes. See page 2.

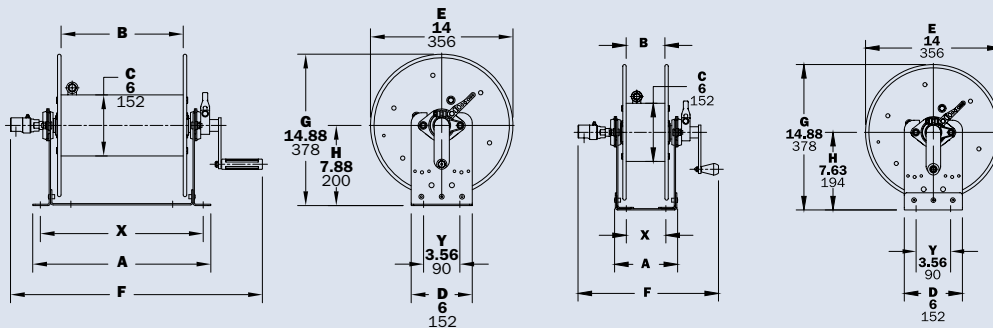

1000 Series shown

MS-1000 Series shown

Series 1500

- Lawn Care • Pest Control • Pressure Washing
- Agriculture • Steam Cleaning

To handle single 3/8" through 5/8" I.D. hose.

- Lightweight, compact reels designed for long lengths of hose in manual and power rewind.
- Manual rewind reels include: cam-lock drag brake, spring actuated pin lock and direct crank rewind.
- Power rewind reels include: chain and sprocket drive powered by electric, hydraulic or air motor.
- Standard inlet: 90° ball bearing swivel joint, 1/2" female NPT threads.
- Standard outlet: 1/2" female NPT threads.
- Standard pressures to 3000 psi (207 bar), available up to 10,000 psi (690 bar) – must specify.
- Standard fluid temperatures from +32° F to +400 °F (0° C to +204° C). Optional temperature ratings available - consult factory.
- Rollers and roller mounting brackets are accessory items. Specify roller position.
- **Heavy-Duty Upgrade Options:** 3/16" thick discs, 8" diameter steel 14 gage drum, and optional pressures of 5000 or 10,000 psi, must specify when ordering.



◀ Standard configuration shown with Electric Rewind (E) option

Standard configuration shown ▶ with Crank Rewind



Optional External Mounting Brackets

Part No. 9906.0027.
Add 2-1/2" to the X dimensions shown in the chart.

PARTS DRAWING – ISO 90 (POWER); ISO 179 (MANUAL)

Model Number <small>For power rewind see Note 5</small>	Hose Capacity of Reel shown in feet /meter				Approx. Weight Crank Rewind shown in lb/kg <small>see Note 3</small>			Reel Dimensions*** shown in inches/millimeter						
	I.D. in. mm	3/8 10	1/2 13	5/8 16	NET	UPS/ FedEx SHIP Wt.	Freight SHIP Wt.	A	B	E CRANK	E POWER	F CRANK	F POWER	X
	O.D. in. mm	3/4 19	7/8 22	1 25										
1514-17-18	125	75	50	27	65*	62	11	6	17.5	19	19.25	17	9.5	
	38	23	15	12	30	28	279	152	445	483	489	432	241	
1520-17-18	275	175	125	29	80*	64	17	12	17.5	19	25.25	23	15.5	
	84	53	38	13	36	29	432	305	445	483	641	584	394	
1526-17-18	400	300	200	31	98*	66	23	18	17.5	19	31.25	29	21.5	
	122	91	61	14	45	30	584	457	445	483	794	737	546	
1530-17-18	500	375	275	33	110*	68	27	22	17.5	19	35.25	33	25.5	
	152	114	84	15	50	31	686	559	445	483	895	838	648	
1536-17-18	-	475	350	35	-	70	33	28	17.5	19	41.25	39	31.5	
	-	145	107	16	-	32	838	711	445	483	1048	991	800	

Notes:

- Specifications subject to change.
- Upon request, reels can be supplied with drum lengths other than shown.
- Weights shown in chart are for crank rewind models. ADD these amounts for power rewind models (does not apply to FedEx or UPS):

	Net lbs/kg	Ship lbs/kg
Electric	18/8.2	18/8.2
Hydraulic	15/6.8	15/6.8
Air	15/6.8	15/6.8

- Dimension "F" is the overall length of standard model reels.
- When ordering power rewind models, prefix model number with:
 - A** = Air Rewind – Supplied with control valve and 18" air hose.

- E** = Electric Rewind – 12v and 24v DC rewind reels are supplied with switch and solenoid; 115v AC rewind reels are not supplied with switch but can be ordered separately.
- HD** = Hydraulic Rewind – Not supplied with control valve.
- 6. Manual rewind available in RT or LB configurations only.
- 7. **Finish:** Refer to page 3.
- 8. **Be sure to check dimensions and weights prior to ordering.**
- 9. Some roller options may prohibit the use of our molded chain guard.

NOTICE: A flexible connector must be used between the inlet pipe and the inlet swivel joint.
* Dimensional weight applies when shipped as a parcel package (via FedEx or UPS Ground).
*** X, Y indicate mounting holes. See page 5.

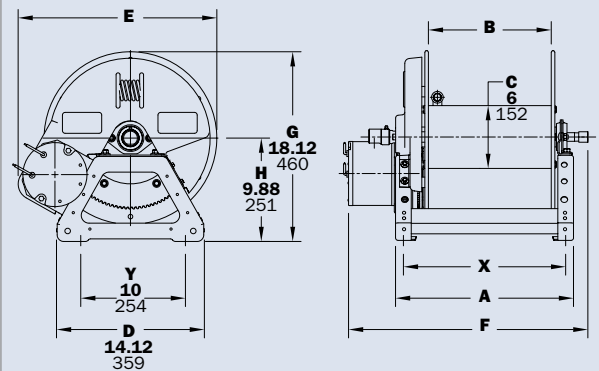

Power rewind shown

Series 1800

• Air Compressors • Washdown

To handle single 5/8" or 3/4" I.D. hose.

- Lightweight, compact reels designed for long lengths of hose in manual and power rewind.
- Manual rewind reels include: cam-lock drag brake, spring actuated pin lock and direct crank rewind.
- Power rewind reels include: chain and sprocket drive powered by electric, hydraulic or air motor.
- Standard inlet: 90° ball bearing swivel joint, 1" female NPT threads.
- Standard outlet: 3/4" female NPT threads.
- Standard pressures to 2000 psi (138 bar), available up to 4000 psi (276 bar) – must specify.
- Standard fluid temperatures from -40° F to +250 °F (-40° C to +121° C). Optional temperature ratings available - consult factory.
- Rollers and roller mounting brackets are accessory items. Specify roller position.



◀ Standard configuration shown with Electric Rewind (E) option



Standard configuration shown ▶ with Crank Rewind



Optional External Mounting Brackets

Part No. 9906.0027.
Add 2-1/2" to the X dimensions shown in the chart.

PARTS DRAWING – ISO 136 (POWER); ISO 180 (MANUAL)

Model Number For power rewind see Note 5	Hose Capacity of Reel shown in feet /meter			Approx. Weight Crank Rewind shown in lb/kg see Note 3			Reel Dimensions*** shown in inches/millimeter						
	I.D. in. mm	5/8 16	3/4 19	NET	UPS/FedEx SHIP Wt.	Freight SHIP Wt.	A	B	E CRANK	E POWER	F CRANK	F POWER	X
	O.D. in. mm	1 25	1-9/32 40										
1816-17-18		75 23	50 15	28 13	80* 36	63 29	13 330	8 203	17.5 445	19 483	23.5 597	19.75 502	11.5 292
1822-17-18		150 46	100 30	30 14	98* 45	65 29	19 483	14 356	17.5 445	19 483	29.5 749	25.75 654	17.5 445
1826-17-18		200 61	125 38	32 15	98* 45	67 30	23 584	18 457	17.5 445	19 483	33.5 851	29.75 756	21.5 546
1830-17-18		250 76	150 46	33 15	110* 50	68 31	27 686	22 559	17.5 445	19 483	37.5 953	33.75 857	25.5 648
1836-17-18		300 91	200 61	36 16	-	71 32	33 838	28 711	17.5 445	19 483	43.5 1105	39.75 1010	31.5 800

Notes:

1. Specifications subject to change.
2. Upon request, reels can be supplied with drum lengths other than shown.
3. Weights shown in chart are for crank rewind models. ADD these amounts for power rewind models (does not apply to FedEx or UPS):

	Net lbs/kg	Ship lbs/kg
Electric	18/8.2	18/8.2
Hydraulic	15/6.8	15/6.8
Air	15/6.8	15/6.8

4. Dimension "F" is the overall length of standard model reels.
5. When ordering power rewind models, prefix model number with:
 - A** = Air Rewind – Supplied with control valve and 18" air hose.

- E** = Electric Rewind – 12v and 24v DC rewind reels are supplied with switch and solenoid; 115v AC rewind reels are not supplied with switch but can be ordered separately.
 - HD** = Hydraulic Rewind – Not supplied with control valve.
6. Manual rewind available in RT or LB configurations only.

7. **Finish:** Refer to page 3.
 8. **Be sure to check dimensions and weights prior to ordering.**
 9. Some roller options may prohibit the use of our molded chain guard.
- NOTICE:** A flexible connector must be used between the inlet pipe and the inlet swivel joint.
* Dimensional weight applies when shipped as a parcel package (via FedEx or UPS Ground).
*** X, Y indicate mounting holes. See page 5.

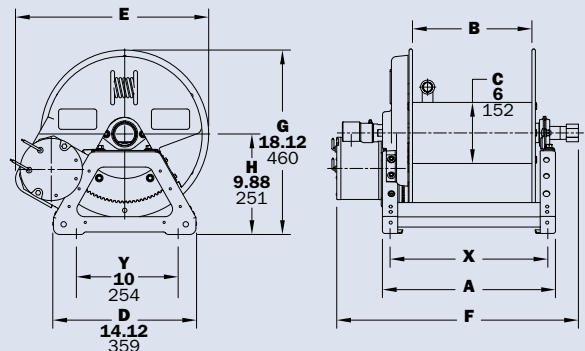

Power rewind shown

Series 2000 | Dual Hose

• Hydraulics • Spray Painting • Air/Water

To handle dual 1/4" through 1/2" I.D. hose.

- Two swivel joint inlets and two outlet risers to handle two equal lengths of hose.
- Chain-driven crank rewind or chain and sprocket rewind powered by an electric or compressed air motor.
- MX crank rewind reels have pinion brake as standard.
- Power rewind reels are not supplied with a brake.
- Standard inlets: 90° ball bearing swivel joints, 1/2" female NPT threads.
- Standard outlets: 1/2" female NPT threads.
- Standard pressures to 3000 psi (207 bar), available up to 10,000 psi (690 bar) – must specify.
- Standard fluid temperatures from -40° F to +250 °F (-40° C to +121° C). Optional temperature ratings available - consult factory.
- Reels for use with oxygen/acetylene. See Series 2400 Hannay Reels Welding Catalog H0408-W.



Standard configuration shown with Electric Rewind (E) option



Optional External Mounting Brackets

Part No. 9906.0027.
Add 2-1/2" to the X dimensions shown in the chart.

PARTS DRAWING – ISO 112

Model Number <small>For power rewind see Note 5</small>	Hose Capacity of Reel shown in feet / meter				Approx. Weight Crank Rewind ³ shown in lb/kg <small>see Note 3</small>			Reel Dimensions ^{**} shown in inches/millimeter						
	I.D. in. mm	1/4 6	3/8 10	1/2 13	NET	UPS/ FedEx SHIP Wt.	Freight SHIP Wt.	A	B	E CRANK	E POWER	F CRANK	F POWER	X
	O.D. in. mm	5/8 16	3/4 19	7/8 22										
2016-17-18	2/100	2/75	2/50	32	80*	67	13	8	19.06	19	21	20.88	11.5	
	2/31	2/23	2/15	15	36	30	330	203	484	483	533	530	292	
2020-17-18	2/175	2/125	2/75	34	98*	69	17	12	19.06	19	25	24.88	15.5	
	2/53	2/38	2/23	15	45	31	432	305	484	483	635	632	394	
2026-17-18	2/275	2/200	2/125	36	110*	71	23	18	19.06	19	31	30.88	21.5	
	2/84	2/61	2/38	16	50	32	584	457	484	483	787	784	546	
2030-17-18	2/350	2/250	2/175	37	-	72	27	22	19.06	19	35	34.88	25.5	
	2/107	2/76	2/53	17	-	33	686	559	484	483	889	886	648	
2036-17-18	2/425	2/300	2/225	39	-	74	33	28	19.06	19	41	40.88	31.5	
	2/130	2/91	2/69	18	-	34	838	711	484	483	1041	1038	800	

Notes:

- Specifications subject to change.
- Upon request, reels can be supplied with drum lengths other than shown.
- Weights shown in chart are for crank rewind models. ADD these amounts for power rewind models (does not apply to FedEx or UPS):

	Net lbs/kg	Ship lbs/kg
Electric	18/8.2	18/8.2
Air	15/6.8	15/6.8
- Dimension "F" is the overall length of standard model reels. MX chain-drive crank models require 2" clearance to remove crank handle.
- When ordering power rewind models, prefix model number with:
 - A** = Air Rewind – Supplied with control valve and 18" air hose.

- E** = Electric Rewind – 12v and 24v DC rewind reels are supplied with switch and solenoid; 115v AC rewind reels are not supplied with switch but can be ordered separately.
- MX** = Chain-Driven Crank.
- 6. Finish:** Refer to page 3.
- 7. Be sure to check dimensions and weights prior to ordering.**
- Some roller options may prohibit the use of our molded chain guard.
- NOTICE:** A flexible connector must be used between the inlet pipe and the inlet swivel joint.
- * Dimensional weight applies when shipped as a parcel package (via FedEx or UPS Ground).
- *** X, Y indicate mounting holes. See page 5.

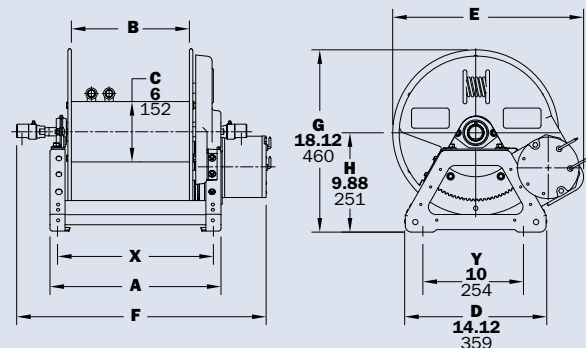

Power rewind shown

Dual Hose | Series **G2000**

• Hydraulics • Spray Painting • Air/Water

To handle dual 1/4" through 1/2" I.D. hose.

- Two swivel joint inlets and two outlet risers to handle two equal lengths of hose.
- Gear-driven crank rewind.
- Pinion brake as standard.
- Standard inlets: 90° ball bearing swivel joints, 1/2" female NPT threads.
- Standard outlets: 1/2" female NPT threads.
- Standard pressures to 3000 psi (207 bar), available up to 10,000 psi (690 bar) – must specify.
- Standard fluid temperatures from -40° F to +250 °F (-40° C to +121° C). Optional temperature ratings available - consult factory.
- For power rewind, see Series 2000, page 20.
- Reels for use with oxygen/acetylene.
See Series 2400 Hannay Reels Welding Catalog H0408-W.



Standard gear-driven crank rewind with optional finish shown



Optional External Mounting Brackets

Part No. 9906.0027.

Add 2-1/2" to the X dimensions shown in the chart.

PARTS DRAWING – ISO 205

Model Number	Hose Capacity of Reel shown in feet /meter				Approx. Weight Crank Rewind shown in lb/kg			Reel Dimensions*** shown in inches/millimeter			
	I.D. in.	1/4	3/8	1/2	NET	UPS/ FedEx SHIP Wt.	Freight SHIP Wt.	A	B	F	X
	mm	6	10	13							
G2016-17-18-8	2/75	2/50	2/35	40	80*	75	13	8	18.88	11.5	
	2/23	2/15	2/11	15	36	34	330	203	480	292	
G2020-17-18-8	2/125	2/100	2/50	42	98*	77	17	12	22.88	15.5	
	2/38	2/31	2/15	18	45	35	432	305	581	394	
G2026-17-18-8	2/200	2/150	2/100	44	110*	79	23	18	28.88	21.5	
	2/61	2/46	2/31	19	50	36	584	457	734	546	

Notes:

1. Specifications subject to change.
2. Upon request, reels can be supplied with drum lengths other than shown.
3. **Finish:** Refer to page 3.
4. **Be sure to check dimensions and weights prior to ordering.**

NOTICE: A flexible connector must be used between the inlet pipe and the inlet swivel joint.

* Dimensional weight applies when shipped as a parcel package (via FedEx or UPS Ground).

*** X, Y indicate mounting holes. See page 5.

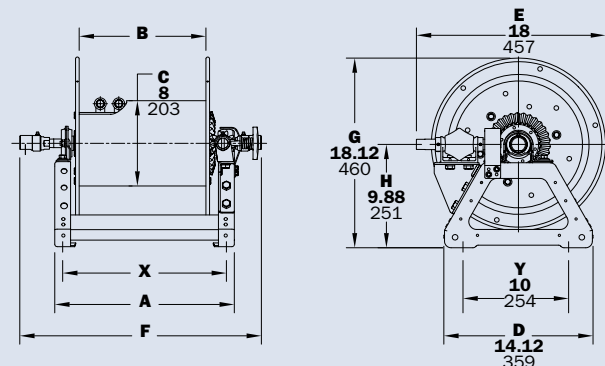

Series 3000

- Fuel Dispensing (Consult Factory) • Spray Operations
- Fire Protection

To handle 3/4" or 1" I.D. hose.

- Economical manual rewind reels for long lengths of hose.
- Choose disc rewind or removable direct crank rewind.
- Supplied with spring actuated pin lock.
- Standard inlet: 90° ball bearing swivel joint, 1" female NPT threads.
- Standard outlet: 1" female NPT thread.
- Standard: inlet, outlet riser, and hub assembly are steel. Options: swivel joint also available in aluminum or stainless steel. Riser and hub assembly also available in stainless steel.
- Standard pressures to 2000 psi (138 bar), available up to 4000 psi (276 bar) – must specify.
- Standard fluid temperatures from -40° F to +250 °F (-40° C to +121° C). Optional temperature ratings available - consult factory.
- Rollers and roller mounting brackets are accessory items. Specify roller position.



Standard configuration shown with crank handle



Optional Aluminum Hand Cart

4300-AL mounting available.

PARTS DRAWING – ISO 113

Model Number	Hose Capacity of Reel shown in feet / meter			Approx. Weight Crank Rewind shown in lb/kg		Reel Dimensions*** shown in inches/millimeter			
	I.D. in.	3/4	1	NET	SHIP	A	B	F	X
	mm	19	25						
3016-25-26-10.5		100	75	85	120	13	7.5	24.5	7.75
		30	23	39	54	330	191	622	197
3020-25-26-10.5		150	100	94	129	17	11.5	28.5	9
		46	30	43	59	432	292	724	229
3024-25-26-10.5		200	125	103	138	21	15.5	32.5	13
		61	38	47	63	533	394	826	330
3028-25-26-10.5		275	175	113	155	25.5	20	37	17.5
		84	53	51	70	648	508	940	445

Notes:

- Specifications subject to change.
 - Upon request, reels can be supplied with drum lengths other than shown and with disc sizes in other diameters.
 - Power rewind NOT available on these models.**
 - Dimension "F" is the overall length of standard model reels. For crank rewind models, 3-1/2" clearance is required to remove crank.
 - Subtract 5" from "F" dimension for disc rewind models.
 - Finish:** Call factory for offshore/marine finish, available at extra cost. Refer to page 3.
 - Be sure to check dimensions and weights prior to ordering.**
- NOTICE:** A flexible connector must be used between the inlet pipe and the inlet swivel joint.
- *** X, Y indicate mounting holes. See page 5.

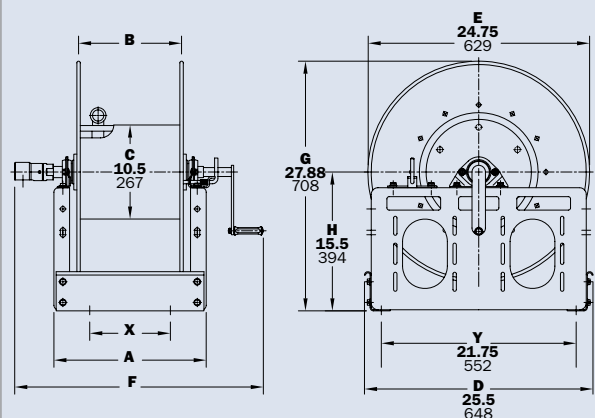

Series 3500

- Fuel Dispensing (Consult Factory) • Bulk Transfer
- Fire Protection

To handle 1-1/4" or 1-1/2" I.D. hose.

- Economical manual rewind reels for long lengths of hose.
- Choose disc rewind or removable direct crank rewind.
- Supplied with spring actuated pin lock.
- Standard inlet: 90° ball bearing swivel joint, 1-1/2" female NPT threads, and 2" Victaulic® groove.
- Standard outlet: 1-1/2" female NPT threads.
- Standard: inlet, outlet riser, and hub assembly are steel. Options: also available in aluminum or stainless steel.
- Standard pressures to 600 psi (41 bar), available up to 1000 psi (69 bar) – must specify.
- Standard fluid temperatures from -20° F to +212 °F (-29° C to +100° C). Optional temperature ratings available - consult factory.
- Rollers and roller mounting brackets are accessory items. Specify roller position.



Standard configuration shown

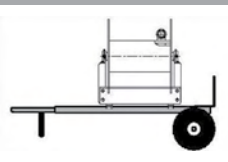

Optional Aluminum Hand Cart

4300-AL mounting available.

PARTS DRAWING – ISO 111

Model Number	Hose Capacity of Reel shown in feet /meter			Approx. Weight Crank Rewind shown in lb/kg		Reel Dimensions*** shown in inches/millimeter								
	I.D. in.	1-1/4	1-1/2	NET	SHIP	A	B	D	E	F	G	H	X	Y
	mm	32	38											
3520-25-26-10.5		75	50	104	139	17	11.5	25.5	24.75	30.75	27.88	15.5	9	21.75
		23	15	47	63	432	292	648	629	781	708	394	229	552
3524-25-26-10.5		100	75	113	157	21	15.5	25.5	24.75	34.75	27.88	15.5	13	21.75
		30	23	51	71	533	394	648	629	883	708	394	330	552
3528-25-26-10.5		150	100	123	173	25.5	20	25.5	24.75	39.25	27.88	15.5	17.5	21.75
		46	30	56	78	648	508	648	629	997	708	394	445	552
3524-30-31-10.5		150	100	124	174	21	15.5	25.5	28.75	34.75	29.88	15.5	13	21.75
		46	30	56	79	533	394	648	730	883	759	394	330	552
3528-30-31-10.5		200	150	134	184	25.5	20	25.5	28.75	39.25	29.88	15.5	17.5	21.75
		61	46	61	83	648	508	648	730	997	759	394	445	552
3534-30-31-10.5		-	200	147	197	31.5	26	25.5	28.75	45.25	29.88	15.5	23.5	21.75
		-	61	67	89	800	660	648	730	1149	759	394	597	552
3530-33-34-10.5		-	250	138	188	27.5	22	31.5	31.75	41.25	32.38	16.5	19.5	27.75
		-	76	63	85	699	559	800	806	1048	822	419	495	705

Notes:

1. Specifications subject to change.
 2. Upon request, reels can be supplied with drum lengths other than shown and with disc sizes in other diameters.
 3. **Power rewind NOT available on these models.**
 4. Dimension "F" is the overall length of standard model reels. For crank rewind models, 3-1/2" clearance is required to remove crank.
 5. Subtract 5" from "F" dimension for disc rewind models.
 6. **Finish:** Call factory for offshore/marine finish, available at extra cost. Refer to page 3.
 7. **Be sure to check dimensions and weights prior to ordering.**
- NOTICE:** A flexible connector must be used between the inlet pipe and the inlet swivel joint.
- *** X, Y indicate mounting holes. See page 5.

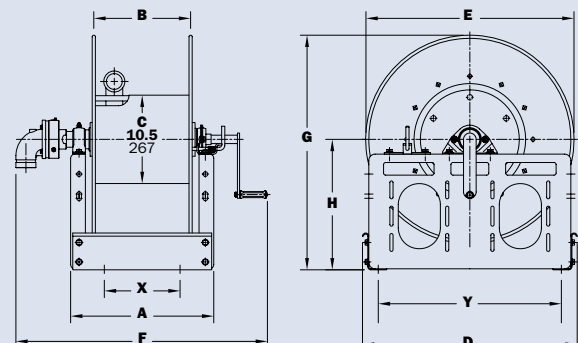

Series 4000

- **Fuel Dispensing** (Consult Factory) • **Water Supply**
- **Fire Protection** • **Chemical Transfer**

To handle single 3/4" or 1" I.D. hose.

- Lightweight, compact reels designed for long lengths of hose in manual and power rewind.
- Manual rewind reels include: cam-lock drag brake, spring actuated pin lock and removable direct crank rewind.
- Power rewind reels include: chain and sprocket drive powered by electric, hydraulic or air. Strap brake is standard.
- Standard inlet: 90° ball bearing swivel joint, 1" female NPT threads.
- Standard outlet: 1" female NPT threads.
- Standard pressures to 2000 psi (138 bar), available up to 4000 psi (276 bar) – must specify.
- Standard fluid temperatures from -40° F to +250 °F (-40° C to +121° C). Optional temperature ratings available - consult factory.
- Rollers and roller mounting brackets are accessory items. Specify roller position.



Standard configuration shown with Electric Rewind (E) option



Optional External Mounting Brackets

Part No. 9906.0027.
Add 2-1/2" to the X dimensions shown in the chart.

PARTS DRAWING – ISO 68 (POWER); ISO 125 (MANUAL)

Model Number For power rewind see Note 5	Hose Capacity of Reel shown in feet /meter			Approx. Weight Crank Rewind shown in lb/kg see Note 3			Reel Dimensions*** shown in inches/millimeter						
	I.D. in. mm	3/4 19	1 25	NET	UPS/ FedEx SHIP Wt.	Freight SHIP Wt.	A	B	E CRANK	E POWER	F CRANK	F POWER	X
	O.D. in. mm	1-9/32 33	1-1/2 38				A	B	E CRANK	E POWER	F CRANK	F POWER	X
4018-17-18	50 15	35 11	36 16	80* 36	71 32	15 381	10 254	17.5 445	19 483	26.5 673	20.75 527	13.5 343	
4024-17-18	100 30	50 15	46 21	98* 45	81 37	21 533	16 406	17.5 445	19 483	32.5 826	26.75 679	19.5 495	
4030-17-18	150 46	75 23	57 26	110* 50	92 42	27 686	22 559	17.5 445	19 483	38.5 978	32.75 832	25.5 648	
4038-17-18	200 61	100 30	70 32	-	124 56	35 889	30 762	17.5 445	19 483	46.5 1181	40.75 1035	33.5 851	

Notes:

- Specifications subject to change.
- Upon request, reels can be supplied with drum lengths other than shown.
- Weights shown in chart are for crank rewind models. ADD these amounts for power rewind models (does not apply to FedEx or UPS):

	Net lbs/kg	Ship lbs/kg
Electric	18/8.2	18/8.2
Hydraulic	15/6.8	15/6.8
Air	15/6.8	15/6.8
- Dimension "F" is the overall length of standard model reels. Crank rewind reels require 3-1/2" clearance to remove or install crank handle.
- When ordering power rewind models, prefix model number with:
 - A** = Air Rewind – Supplied with control valve and 18" air hose.

- E** = Electric Rewind – 12v and 24v DC rewind reels are supplied with switch and solenoid; 115v AC rewind reels are not supplied with switch but can be ordered separately.
 - HD** = Hydraulic Rewind – Not supplied with control valve.
 - 6. **Finish:** Refer to page 3.
 - 7. **Be sure to check dimensions and weights prior to ordering.**
 - 8. Some roller options may prohibit the use of our molded chain guard.
- NOTICE:** A flexible connector must be used between the inlet pipe and the inlet swivel joint.
* Dimensional weight applies when shipped as a parcel package (via FedEx or UPS Ground).
*** X, Y indicate mounting holes. See page 5. (Also applies for external mounting brackets.)

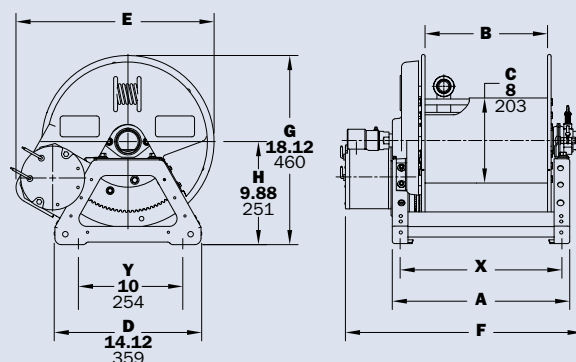

Power rewind shown

Series 4100

- Fuel Dispensing (Consult Factory) • Water Supply
- Fire Protection • Chemical Transfer

To handle single 3/4" or 1" I.D. hose.

- Lightweight, compact reels designed for long lengths of hose in manual and power rewind.
- Manual rewind reels include: gear-driven crank rewind with removable handle and adjustable brake.
- Power rewind reels include: chain and sprocket drive powered by electric, hydraulic or air motor.
- Standard inlet: 90° ball bearing swivel joint, 1" female NPT threads.
- Standard outlet: 1" female NPT threads.
- Standard pressures to 2000 psi (138 bar), available up to 4000 psi (276 bar) – must specify.
- Standard fluid temperatures from -40° F to +250 °F (-40° C to +121° C). Optional temperature ratings available - consult factory.
- Rollers and roller mounting brackets are accessory items. Specify roller position.



Standard configuration shown with Electric Rewind (E) option and gear-driven crank rewind and optional finish shown

PARTS DRAWING – ISO 216

Model Number For power rewind see Note 5	Hose Capacity of Reel shown in feet /meter			Approx. Weight Crank Rewind shown in lb/kg see Note 3		Reel Dimensions*** shown in inches/millimeter					
	I.D. in. mm	3/4 19	1 25	NET	SHIP	A	B	E CRANK	E POWER	F	X
	O.D. in. mm	1-9/32 33	1-1/2 38								
4118-17-18		50 15	35 11	62 28	97 44	15 381	10 254	18 457	20.5 521	21.5 546	7.5 190
4124-17-18		100 30	50 15	72 33	107 49	21 533	16 406	18 457	20.5 521	27.5 699	13.5 343
4130-17-18		150 46	75 23	83 38	118 54	27 686	22 559	18 457	20.5 521	33.5 851	19.5 495
4138-17-18		200 61	100 30	96 44	131 59	35 889	30 762	18 457	20.5 521	41.5 1054	27.5 698

Notes:

- Specifications subject to change.
- Upon request, reels can be supplied with drum lengths other than shown.
- Weights shown in chart are for crank rewind models. ADD these amounts for power rewind models:

	Net lbs/kg	Ship lbs/kg
Electric	18/8.2	18/8.2
Hydraulic	15/6.8	15/6.8
Air	15/6.8	15/6.8
- Dimension "F" is the overall length of standard model reels.
- When ordering standard gear rewind models, prefix model number with:
A = Air Rewind –
 Supplied with control valve and 18" air hose.

- E = Electric Rewind –**
 12v and 24v DC rewind reels are supplied with switch and solenoid; 115v AC rewind reels are not supplied with switch but can be ordered separately.
- HD = Hydraulic Rewind –**
 Not supplied with control valve.
- 6. Finish:** Refer to page 3.
- 7. Be sure to check dimensions and weights prior to ordering.**

NOTICE: A flexible connector must be used between the inlet pipe and the inlet swivel joint.
 *** X, Y indicate mounting holes. See page 5.

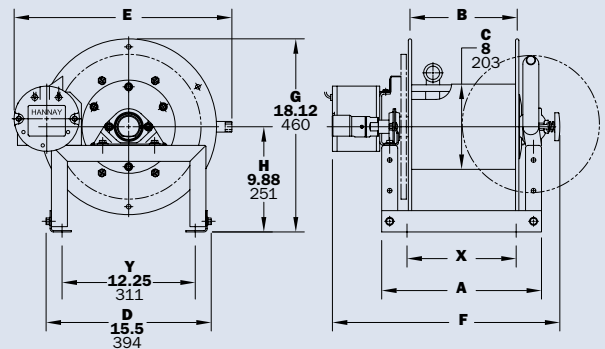

Power rewind shown

Series 6000

- Fuel Dispensing (Consult Factory) • Fire Protection
- Spray Operations • Water Blasting* • Sewer Cleaning*

To handle single 1/2" through 1" I.D. hose.

- Heavy-duty reel for longer lengths of hose.
- Choose gear-driven crank rewind or chain and sprocket drive powered by an electric, hydraulic or compressed air motor.
- Crank rewind reels supplied with pinion brake; power rewind reels with a strap brake.
- Standard inlet: 90° ball bearing swivel joint, 1" female NPT threads.
- Standard outlet: 1" female NPT threads.
- Standard: inlet, outlet riser, and hub assembly are steel. Options: swivel joint also available in aluminum or stainless steel. Riser and hub assembly also available in stainless steel.
- Standard pressures to 2000 psi (138 bar), available up to 5000 psi (345 bar) – must specify.
- Standard fluid temperatures from -40° F to +250 °F (-40° C to +121° C). Optional temperature ratings available - consult factory.
- Rollers and roller mounting brackets are accessory items. Specify roller position.
- Consult factory for optional chain guard.

* Heavy-duty construction required for water blasting and sewer cleaning applications. Consult factory.



Standard configuration shown with Electric Rewind (EP) option



Optional Auxiliary Rewind

Ring and pinion shaft rewind unit with removable crank handle.



Optional Assembly C2 roller top wind and auxiliary rewind shown

Series 6000

- Fuel Dispensing (Consult Factory) • Fire Protection
- Spray Operations • Water Blasting* • Sewer Cleaning*

PARTS DRAWING – ISO 84

Model Number For power rewind see Note 5	Hose Capacity of Reel shown in feet / meter				Approx. Weight Crank Rewind shown in lb/kg see Note 4		Reel Dimensions*** shown in inches/millimeter									
	I.D. in. mm	1/2 13	3/4 19	1 25	NET	SHIP	A	B	D	E	F CRANK	F POWER	G	H	X	Y
	O.D. in. mm	7/8 22	1-9/32 33	1-1/2 38												
6024-19-21-10.5	200	100	60	85	85	127	21	15.5	20.5	18.75	25.38	28.75	21.5	12.12	13	16.75
	61	30	18	39	39	58	533	394	521	476	645	730	546	308	330	425
6032-19-21-10.5	325	175	85	102	144		29.5	24	20.5	18.75	33.88	37.25	21.5	12.12	21.5	16.75
	99	53	26	46	65		749	610	521	476	861	946	546	308	546	425
6024-23-24-10.5	400	150	125	92	134		21	15.5	20.5	22.75	25.38	28.75	23.5	12.12	13	16.75
	122	46	38	42	61		533	394	521	578	645	730	597	308	330	425
6030-23-24-10.5	-	225	200	105	147		27.5	22	20.5	22.75	31.88	35.25	23.5	12.12	19.5	16.75
	-	68	61	48	67		699	559	521	578	810	895	597	308	495	425
6038-23-24-10.5	-	300	250	120	162		35	29.5	20.5	22.75	39.38	42.75	23.5	12.12	27	16.75
	-	91	76	54	73		889	749	521	578	1000	1086	597	308	686	425
6016-25-26-10.5	250	100	75	88	130		13	7.5	25.5	24.75	17.38	20.75	27.88	15.5	7.75	21.75
	76	30	23	40	59		330	191	648	629	441	527	708	394	197	552
6022-25-26-10.5	450	175	125	100	142		19	13.5	25.5	24.75	23.38	26.75	27.88	15.5	11	21.75
	137	84	38	45	64		483	343	648	629	594	679	708	394	279	552
6028-25-26-10.5	-	275	175	113	155		25.5	20	25.5	24.75	29.88	33.25	27.88	15.5	17.5	21.75
	-	84	53	51	70		648	508	648	629	759	845	708	394	445	552
6018-30-31-10.5	400	200	150	101	151		15	9.5	25.5	28.75	19.38	22.75	29.88	15.5	7	21.75
	122	61	46	46	68		381	241	648	730	492	578	759	394	178	552
6024-30-31-10.5	-	350	250	113	163		21	15.5	25.5	28.75	25.38	28.75	29.88	15.5	13	21.75
	-	107	76	51	74		533	394	648	730	645	730	759	394	330	552
6028-30-31-10.5	-	-	300	121	171		25.5	20	25.5	28.75	29.88	33.25	29.88	15.5	17.5	21.75
	-	-	91	55	78		648	508	648	730	759	845	759	394	445	552
† 6028-33-34-10.5	-	-	400	129	179		25	20	31.5	31.75	29.75	33	33.63	17.75	17.5	27.75
	-	-	122	59	81		635	508	800	806	756	838	854	451	445	705

Notes:

- Specifications subject to change.
- Upon request, reels can be supplied with drum lengths other than shown and with disc sizes in other diameters.
- Dimensions shown for reels up to and including 30-31 disc size reflect pressed frames. All others are rollformed channel frames.
- Weights shown in chart are for crank rewind models. ADD these amounts for power rewind models.

Net lbs/kg Ship lbs/kg

Electric	40/18.1	40/18.1
Hydraulic	20/9.1	20/9.1
Air	20/9.1	20/9.1

- When ordering power rewind models, prefix model number with:
 - A** = Air Rewind – Supplied with control valve and 18" air hose.
 - EP** = Electric Rewind (1/2 HP) – 12v and 24v DC rewind reels are supplied with switch and solenoid; 115v AC rewind reels are not supplied with switch but can be ordered separately.

EPJ = Explosion Proof Electric Rewind (1/2 HP) (supplied with explosion proof switch, solenoid, and junction box).
NOTE: ADD 1.5" to F dimension for EPJ models.

HD = Hydraulic Rewind – Not supplied with control valve.

6. **Finish:** Refer to page 3.

7. **Be sure to check dimensions and weights prior to ordering.**

NOTICE: A flexible connector must be used between the inlet pipe and the inlet swivel joint.

*** X, Y indicate mounting holes. See page 5.

† Some applications require a clutch/reduction unit.

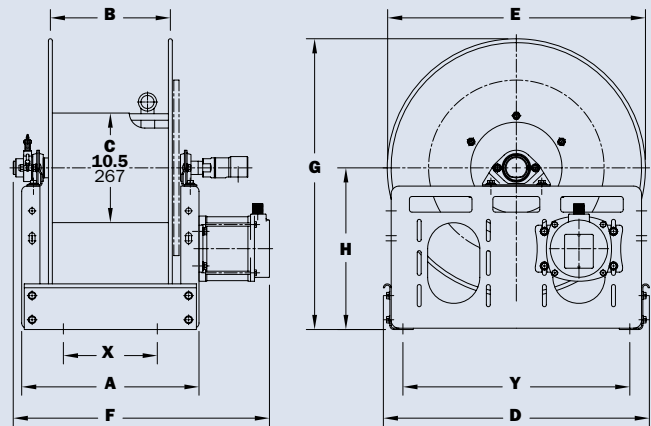

Power rewind shown

Series 7000 | Dual Hose

• Hydraulics • Dual Agents

To handle dual 3/4" or 1" I.D. hose.

- Two swivel joint inlets and two outlet risers to handle two equal lengths of hose.
- Choose gear-driven crank rewind or chain and sprocket drive powered by an electric, hydraulic or compressed air motor. An auxiliary rewind is standard.
- Crank rewind and power rewind reels, pinion brake is standard.
- Standard inlets: 90° ball bearing swivel joints, 1" female NPT threads.
- Standard outlets: 1" female NPT threads.
- Standard: inlet, outlet riser, and hub assembly are steel. Options: swivel joint also available in aluminum or stainless steel. Riser and hub assembly also available in stainless steel.
- Standard pressures to 2000 psi (138 bar), available up to 5000 psi (345 bar) – must specify.
- Standard fluid temperatures from -40° F to +250° F (-40° C to +121° C). Optional temperature ratings available - consult factory.
- Consult factory for optional chain guard.



Standard configuration shown with Electric Rewind (EP) option

PARTS DRAWING – ISO 72

Model Number For power rewind see Note 5	Hose Capacity of Reel shown in feet /meter			Approx. Weight Crank Rewind shown in lb/kg see Note 4		Reel Dimensions*** shown in inches/millimeter									
	I.D. in. mm	3/4 19	1 25	NET	Freight SHIP Wt.	A	B	D	E	F CRANK	F POWER	G	H	X	Y
	O.D. in. mm	1-9/32 33	1-1/2 38			21	15.5	20.5	21.88	29.75	32.12	21.5	12.12	13	16.75
7024-19-21-10.5		2/60	2/25	100	142	21	15.5	20.5	21.88	29.75	32.12	21.5	12.12	13	16.75
		2/18	2/8	45	64	533	394	521	556	756	816	546	308	330	425
7026-23-24-10.5		2/90	2/50	105	147	23	17.5	20.5	23	31.75	34.12	23.5	12.12	15	16.75
		2/27	2/15	48	67	584	445	521	584	806	867	597	308	381	425
7032-25-26-10.5		2/175	2/100	129	179	29.5	24	25.5	24.75	38.25	40.62	27.88	15.5	21.5	21.75
		2/53	2/31	59	81	749	610	648	629	972	1032	708	394	546	552
† 7032-30-31-10.5		2/300	2/175	137	187	29.5	24	25.5	28.75	38.25	40.62	29.88	15.5	21.5	21.75
		2/91	2/53	62	85	749	610	648	730	972	1032	759	394	546	552
† 7024-33-34-10.5		2/225	2/150	120	170	20.5	15.5	31.5	31.75	29.75	32.12	33.62	17.75	13	27.75
		2/69	2/46	54	77	521	394	800	806	756	816	854	451	330	705
† 7032-33-34-10.5		2/350	2/225	137	187	29	24	31.5	31.75	38.25	40.62	33.62	17.75	21.5	27.75
		2/107	2/69	62	85	737	610	800	806	972	1032	854	451	546	705

Notes:

1. Specifications subject to change.
2. Upon request, reels can be supplied with drum lengths other than shown and with disc sizes in other diameters.
3. Dimensions shown for reels up to and including 30-31 disc size reflect pressed frames. All others are rollformed channel frames.
4. Weights shown in chart are for crank rewind models. ADD these amounts for power rewind models.

	Net lbs/kg	Ship lbs/kg
Electric	40/18.1	40/18.1
Hydraulic	20/9.1	20/9.1
Air	20/9.1	20/9.1

5. When ordering, prefix model number with:
 - A** = Air Rewind – Supplied with control valve and 18" air hose.
 - EP** = Electric Rewind (1/2 HP) – 12v and 24v DC rewind reels are supplied with switch and solenoid; 115v AC rewind reels are not supplied with switch but can be ordered separately.
 - HD** = Hydraulic Rewind – Not supplied with control valve.
 - MX** = Chain-Driven Crank.
6. **Finish:** Refer to page 3.
7. **Be sure to check dimensions and weights prior to ordering.**

NOTICE: A flexible connector must be used between the inlet pipe and the inlet swivel joint.
 *** X, Y indicate mounting holes. See page 5.
 † Some applications require a clutch/reduction unit.

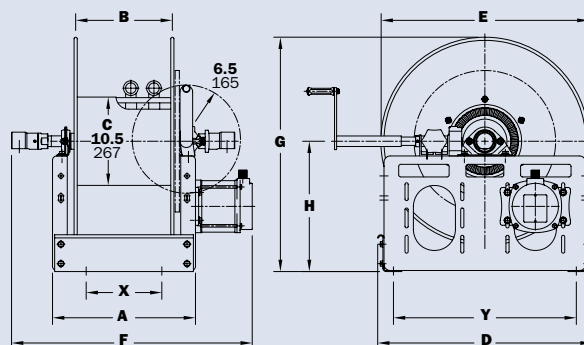

Power rewind shown

Series 7500

- Fuel Dispensing (Consult Factory) • Bulk Transfer
- Suction/Discharge (Consult Factory)

To handle single 1-1/4" or 1-1/2" I.D. hose.

- Choose gear-driven crank rewind or chain and sprocket drive powered by an electric, hydraulic or compressed air motor.
- Crank rewind reels supplied with pinion brake and power rewind reels with a strap brake.
- Standard inlet: 90° ball bearing swivel joint, 1-1/2" female NPT threads, and 2" Victaulic® groove.
- Standard outlet: 1-1/2" female NPT threads.
- Standard: inlet, outlet riser, and hub assembly are steel. Options: also available in aluminum or stainless steel.
- Standard pressures to 1000 psi (41 bar), consult factory for other pressure ratings – must specify.
- Standard fluid temperatures from -20° F to +212 °F (-29° C to +100° C). Optional temperature ratings available - consult factory.
- Rollers and roller mounting brackets are accessory items. Specify roller position.
- Consult factory for optional chain guard.



Standard configuration shown with Electric Rewind (EP) option



Optional Auxiliary Rewind

Ring and pinion shaft rewind unit with removable crank handle.

PARTS DRAWING – ISO 18

Model Number For power rewind see Note 5	Hose Capacity of Reel shown in feet /meter			Approx. Weight Crank Rewind shown in lb/kg see Note 4		Reel Dimensions*** shown in inches/millimeter									
	I.D. in. mm	1-1/4 32	1-1/2 38	NET	SHIP	A	B	D	E	F CRANK	F POWER	G	H	X	Y
	O.D. in. mm	1-13/16 46	2-1/16 52			25.5	20	20.5	18.75	32	33.25	21.5	12.12	17.5	16.75
7528-19-21-10.5	70	50	104	146	25.5	20	20.5	18.75	32	33.25	21.5	12.12	17.5	16.75	
	21	15	47	66	648	508	521	476	813	845	546	308	445	425	
7538-23-24-10.5	175	100	130	172	35	29.5	20.5	22.75	41.5	42.75	23.5	12.12	27	16.75	
	53	30	59	78	889	749	521	578	1054	1086	597	308	686	425	
7520-25-26-10.5	75	50	106	148	17	11.5	25.5	24.75	23.5	24.75	27.88	15.5	9	21.75	
	23	15	48	67	432	292	648	629	597	629	708	394	229	552	
7528-25-26-10.5	125	100	123	165	25.5	20	25.5	24.75	32	33.25	27.88	15.5	17.5	21.75	
	38	30	56	75	648	508	648	629	813	845	708	394	445	552	
7522-30-31-10.5	125	100	118	168	19	13.5	25.5	28.75	25.5	26.75	29.88	15.5	11	21.75	
	38	30	54	76	483	343	648	730	648	679	759	394	279	552	
†7528-30-31-10.5	200	150	131	181	25.5	20	25.5	28.75	32	33.25	29.88	15.5	17.5	21.75	
	61	46	59	82	648	508	648	730	813	845	759	394	445	552	
†7526-33-34-10.5	200	175	133	183	22.5	17.5	31.5	31.75	29.25	30.5	33.62	17.75	15	27.75	
	61	53	60	83	572	445	800	806	743	775	854	451	381	705	

Notes:

- Specifications subject to change.
- Upon request, reels can be supplied with drum lengths other than shown and with disc sizes in other diameters.
- Dimensions shown for reels up to and including 30-31 disc size reflect pressed frames. All others are rollformed channel frames.
- Weights shown in chart are for crank rewind models. ADD these amounts for power rewind models.

	Net lbs/kg	Ship lbs/kg
Electric	40/18.1	40/18.1
Hydraulic	20/9.1	20/9.1
Air	20/9.1	20/9.1

- When ordering, prefix model number with:
 - A** = Air Rewind – Supplied with control valve and 18" air hose.

- EP** = Electric Rewind (1/2 HP) – 12v and 24v DC rewind reels supplied with switch and solenoid; 115v AC rewind reels not supplied with switch but can be ordered separately.
- EPJ** = Explosion Proof Electric Rewind (1/2 HP) (supplied with explosion proof switch, solenoid, and junction box). **NOTE: ADD 1.5"** to F dimension for EPJ models.
- HD** = Hydraulic Rewind – Not supplied with control valve.

6. **Finish:** Refer to page 3.

7. **Be sure to check dimensions and weights prior to ordering.**

NOTICE: A flexible connector must be used between the inlet pipe and the inlet swivel joint.

*** X, Y indicate mounting holes. See page 5.

†Some applications require a clutch/reduction unit.

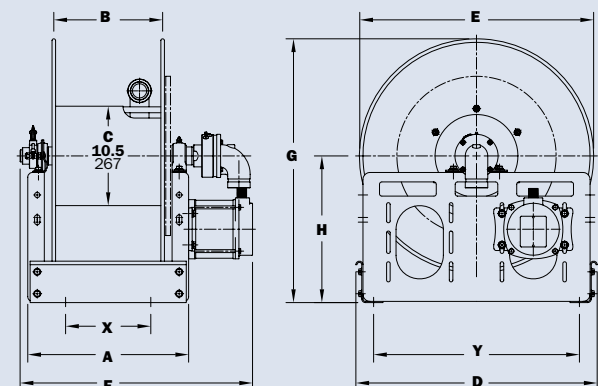

Power rewind shown

Series 8000

- Bulk Transfer • Fueling Applications (Consult Factory)
- Chemical Transfer • General Dispensing • Suction/Discharge (Consult Factory)

To handle single 1-1/2" or 2" I.D. hose.

- Heavy-duty reel designed for longer lengths and larger diameters of hose through 2" I.D.
- Choose gear-driven crank rewind or chain and sprocket drive powered by an electric, hydraulic or compressed air motor.
- Crank rewind reels supplied with a pinion brake; power rewind reels with a strap brake.
- Standard inlet: 90° ball bearing swivel joint, 2" female NPT threads.
- Standard outlet: 2" female NPT threads.
- Standard: inlet, outlet riser, and hub assembly are steel. Options: also available in aluminum or stainless steel.
- Pressures to 600 psi (41 bar). Standard fluid temperatures from -20° F to +212 °F (-29° C to +100° C). Consult factory for other pressures and temperatures.
- Rollers and roller mounting brackets are accessory items. Specify roller position.
- Consult factory for optional chain guard.



Standard configuration shown with Electric Rewind (EP) option



Inline Gearbox

For use on power reels with disc diameter 39" or larger and/or when increased torque and slower rewind speeds are required. Factory installed when specified or available as an accessory item.

PARTS DRAWING – ISO 35

Model Number For power rewind see Note 4	Hose Capacity of Reel shown in feet / meter			Approx. Weight Crank Rewind shown in lb/kg see Note 3		Reel Dimensions*** shown in inches/millimeter									
	I.D. in. mm	1-1/2 38	2 51	NET	SHIP	A	B	D	E	F CRANK	F POWER	G	H	X	Y
	O.D. in. mm	2-1/16 52	2-9/16 65			26.25 667	20 508	27 686	25.75 654	33.75 857	34 864	26.62 676	13.75 349	18.75 476	23.25 591
8234-26-27-15.5	80 24	60 18	120 54	170 77	26.25 667	20 508	27 686	25.75 654	33.75 857	34 864	26.62 676	13.75 349	18.75 476	23.25 591	
8238-26-27-15.5	100 30	75 23	145 66	195 88	30.25 768	24 610	27 686	25.75 654	37.75 959	38 965	26.62 676	13.75 349	22.75 578	23.25 591	
8246-26-27-15.5	145 44	100 30	196 89	245 112	38.25 972	32 813	27 686	25.75 654	45.75 1162	46 1168	26.62 676	13.75 349	30.75 781	23.25 591	
8226-33-34-15.5	85 26	60 18	80 36	150 68	17.75 451	11.5 292	31.5 800	31.75 806	25.25 641	25.5 648	33.38 848	17.75 445	10.25 260	27.75 705	
8234-33-34-15.5	150 46	115 35	133 60	230 105	26.25 667	20 508	31.5 800	31.75 806	33.75 857	34 864	33.38 848	17.75 445	18.75 476	27.75 705	
8238-39-40-15.5	340 104	225 69	218 99	420 191	30.25 768	24 610	40 1016	39 991	37.75 959	38 965	39.88 1013	20.38 518	22.75 578	36.75 933	

Notes:

- Specifications subject to change.
- Upon request, reels can be supplied with drum lengths other than shown and with disc sizes in other diameters.
- Weights shown in chart are for crank rewind models. ADD these amounts for power rewind models.

	Net lbs/kg	Ship lbs/kg
Electric	40/18.1	40/18.1
Hydraulic	20/9.1	20/9.1
Air	20/9.1	20/9.1
- When ordering power rewind models, prefix model number with:
A = Air Rewind – Supplied with control valve and 18" air hose.

- EP** = Electric Rewind (1/2 HP) – 12v and 24v DC rewind reels supplied with switch and solenoid; 115v AC rewind reels not supplied with switch but can be ordered separately.
- EPJ** = Explosion Proof Electric Rewind (1/2 HP) (supplied with explosion proof switch, solenoid, and junction box). **NOTE: ADD 1.5"** to F dimension for EPJ models.
- HD** = Hydraulic Rewind – Not supplied with control valve.
- 5. Finish:** Refer to page 3.
- 6. Be sure to check dimensions and weights prior to ordering.**
- NOTICE:** A flexible connector must be used between the inlet pipe and the inlet swivel joint.
- *** X, Y indicate mounting holes. See page 5.

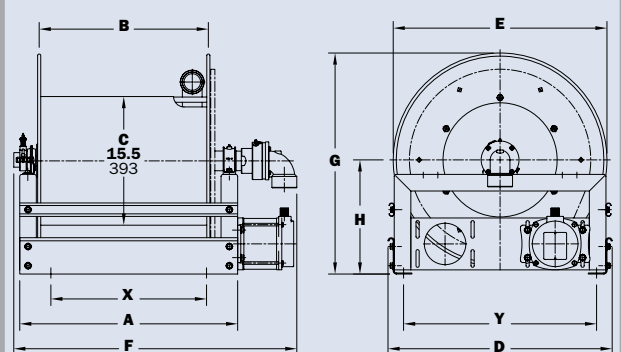

Power rewind shown

Series 9000

- Fueling Applications (Consult Factory) • Bulk Transfer
- Suction/Discharge (Consult Factory) • High Volume Application • Chemical Transfer

To handle 2-1/2" or 3" I.D. hose.

- Heavy-duty reel designed for longer lengths and larger diameters of hose through 3" I.D.
- Choose gear-driven crank rewind or chain and sprocket drive powered by an electric, hydraulic or compressed air motor.
- Crank rewind reels supplied with a pinion brake; power rewind reels with a strap brake.
- Standard inlet: 90° ball bearing swivel joint, 3" female NPT threads.
- Standard outlet: 3" female NPT threads.
- Standard: outlet riser, and hub assembly are aluminum with ductile inlet.
Options: swivel joint also available in aluminum or stainless steel. Riser and hub assembly also available in stainless steel.
- Pressures to 300 psi (21 bar). Standard fluid temperatures from -20° F to +212 °F (-29° C to +100° C). Consult factory for other pressures and temperatures.
- Rollers and roller mounting brackets are accessory items. Specify roller position.
- Consult factory for optional chain guard.



Standard configuration shown with Electric Rewind (EP) option



Inline Gearbox

For use on power reels with disc diameter 39" or larger and/or when increased torque and slower rewind speeds are required. Factory installed when specified or available as an accessory item.

PARTS DRAWING – ISO 57

Model Number For power rewind see Note 4	Hose Capacity of Reel shown in feet /meter			Approx. Weight Crank Rewind shown in lb/kg see Note 3		Reel Dimensions*** shown in inches/millimeter									
	I.D. in. mm	2-1/2 64	3 76	NET	SHIP	A	B	D	E	F CRANK	F POWER	G	H	X	Y
	O.D. in. mm	3-3/16 81	3-3/4 95			23.75	17.5	31.5	31.75	33.75	34.38	33.88	18	16.25	27.75
9332-33-34-20		30	25	147	217	603	445	800	80	857	873	861	457	413	705
9338-33-34-20		45	35	187	257	768	610	800	807	1022	1038	861	457	578	705
9346-33-34-20		60	50	237	372	972	813	800	807	1226	1242	861	457	781	705
9338-39-40-20		90	80	239	480	768	610	1016	991	1022	1038	1026	530	578	933
9334-45-46-20		130	115	361	525	667	508	1168	1143	921	937	1178	607	476	1086

Notes:

- Specifications subject to change.
- Upon request, reels can be supplied with drum lengths other than shown and with disc sizes in other diameters.
- Weights shown in chart are for crank rewind models. ADD these amounts for power rewind models.

	Net lbs/kg	Ship lbs/kg
Electric	40/18.1	40/18.1
Hydraulic	20/9.1	20/9.1
Air	20/9.1	20/9.1

- When ordering power rewind models, prefix model number with:
A = Air Rewind – Supplied with control valve and 18" air hose.

- EP** = Electric Rewind (1/2 HP) – 12v and 24v DC rewind reels supplied with switch and solenoid; 115v AC rewind reels not supplied with switch but can be ordered separately.
 - EPJ** = Explosion Proof Electric Rewind (1/2 HP) (supplied with explosion proof switch, solenoid, and junction box).
 - HD** = Hydraulic Rewind – Not supplied with control valve.
 - 5. Finish:** Refer to page 3.
 - 6. Be sure to check dimensions and weights prior to ordering.**
- NOTICE:** A flexible connector must be used between the inlet pipe and the inlet swivel joint.
*** X, Y indicate mounting holes. See page 5.

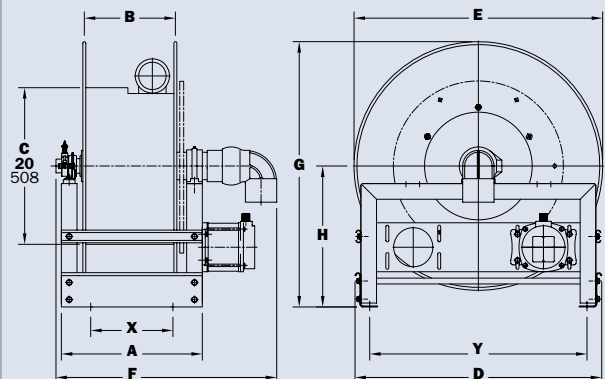

Power rewind shown

Series **1100/AT1200**

- Grounds Maintenance • Restaurants/Hotels
- Washdown Operations • Home Use

To handle 3/8" through 1" I.D. hose.

- Continuous flow reels with swivel joint inlet, fluid hub, outlet riser.
- Direct crank rewind and cam-lock drag brake.
- One-piece foot and removable steel handlebar.
- **GH** prefix to model number (e.g., GH1100, GHAT1200) includes garden hose thread on outlet, 5' lead-in hose, hose end clips.

Model 1100

- Standard inlet: 90° ball bearing swivel joint, 1/2" female NPT threads.
- Standard outlet: 1/2" female NPT threads.
- Pressures to 3000 psi (207 bar).
- Standard fluid temperatures from +32° F to +400 °F (0° C to +204° C). Optional temperature ratings available - consult factory.
- Rubber tires standard. Oversized pneumatic tires available specify "AT" in model number when ordering.

Model AT1200

- Standard inlet: 90° balance pressure swivel joint, 1" female NPT threads.
- Standard outlet: 1" female NPT threads.
- Standard pressures to 2000 psi (138 bar), available up to 4000 psi (276 bar) – must specify.
- Standard fluid temperatures from -40° F to +250 °F (-40° C to +121° C). Optional temperature ratings available - consult factory.
- Pneumatic tires standard.



GH1100

Standard configuration shown in optional green powder coat finish



GHAT1200

Standard configuration shown

PARTS DRAWING – 1100–ISO 48; AT1200–ISO 87

Model Number	Hose Capacity of Reel shown in feet /meter						Approx. Weight shown in lb/kg		Reel Dimensions shown in inches/millimeter								
	I.D. in.	3/8	1/2	5/8	3/4	1	NET	SHIP	A	B	C	D	E	F	G	H	
	mm	10	13	16	19	25											O.D. in.
1100		275	175	125	-	-	47	100*	21.25	12	6	20.12	16.5	25.25	42.5	14.38	
		84	53	38	-	-	21	46	540	305	152	511	419	641	1080	365	
AT1200		-	350	250	150	100	86	147*	25.88	11.5	8	22.62	22.75	27	42.5	18.12	
		-	107	76	46	30	39	67	657	292	203	575	578	686	1080	460	

Notes:

1. Specifications subject to change.
2. Some assembly required.
3. **Finish:** Refer to page 3.
4. **Be sure to check dimensions and weights prior to ordering.**

*Dimensional weight applies when shipped as a parcel package (via FedEx or UPS Ground).

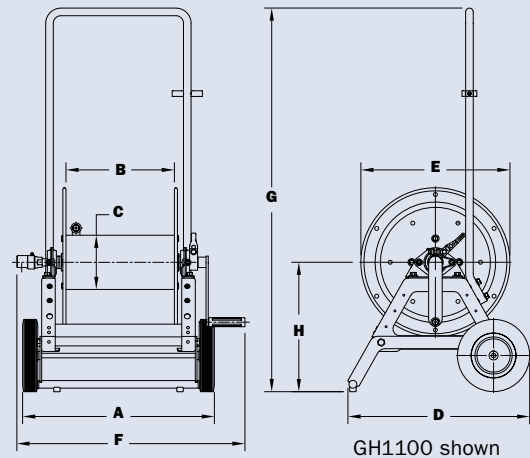

Series **C1150/ATC1250**

- Industrial Maintenance • Construction
- Agriculture • Grounds Maintenance

For storage of hose, cable, rope or wire.

- Direct crank rewind and cam-lock drag brake.
- One-piece foot and removable steel handlebar.

Model C1150

- A 1-1/8" x 2-3/8" (28 mm x 60 mm) opening in the drum to initiate winding.
- Rubber tires standard.

Model ATC1250

- A larger version of the C1150 with a 4-1/2" x 9" (114 mm x 229 mm) drum opening.
- Pneumatic tires standard.



C1150

Standard configuration shown

ATC1250

Standard configuration shown



Optional Folding Handle

For compact storage

PARTS DRAWING – C1150–ISO 48; ATC1250–ISO 87

Model Number	Cable Capacity of Reel shown in feet /meter				Approx. Weight shown in lb/kg		Reel Dimensions shown in inches/millimeter								
	O.D. in. mm	Gauge/Number of Conductors				NET	SHIP	A	B	C	D	E	F	G	H
		16/3	14/3	12/3	10/3										
C1150	1100	500	400	300	44	100*	21.25	12	6	20.12	16.5	24.62	42.5	14.38	
	335	152	122	91	20	46	540	305	152	511	419	625	1080	365	
ATC1250	1800	950	750	550	84	147*	25.88	11.5	8	22.62	22.75	27	42.5	18.12	
	549	290	229	168	38	67	657	292	203	575	578	686	1080	460	

Notes:

1. Specifications subject to change.
2. Some assembly required.
3. When ordering specify model number, O.D., length, and weight of cable, hose, etc.
4. **Finish:** Refer to page 3.
5. **Be sure to check dimensions and weights prior to ordering.**

*Dimensional weight applies when shipped as a parcel package (via FedEx or UPS Ground).

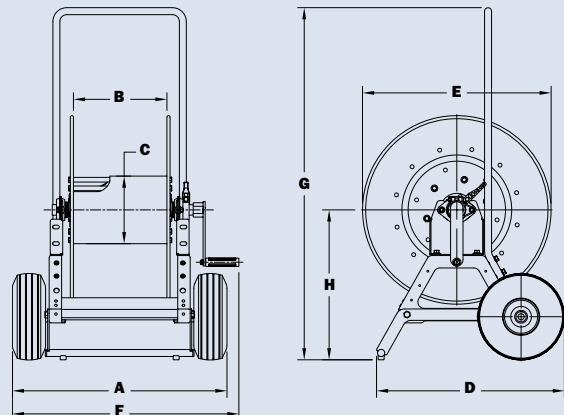

ATC1250 Shown

Series C1500

• Hose • Rope • Cable • Wire

To handle single 1/4" through 1" O.D.

- Reels are designed for storage of long lengths of hose, cable, rope, wire or other materials.
- A 1-1/8" x 2-3/8" (28 mm x 60 mm) opening in the drum to initiate winding.
- Manual rewind reels include: cam-lock drag brake, spring actuated pin lock and direct crank rewind.
- Power rewind reels include: chain and sprocket drive powered by electric, hydraulic or air motor.
- Optional divider discs can be placed at almost any point. Be sure to specify spacing of discs on your order.
- Rollers and roller mounting brackets are accessory items. Specify roller position.



Standard configuration with optional finish shown



Optional External Mounting Brackets

Part No. 9906.0027.
Add 2-1/2" to the X dimensions shown in the chart.

PARTS DRAWING – ISO 218

Model Number <small>For power rewind see Note 5</small>	Hose Capacity of Reel shown in feet /meter					Approx. Weight Crank Rewind shown in lb/kg see Note 4			Reel Dimensions*** shown in inches/millimeter					
	O.D. in. mm	1/4 6	1/2 13	3/4 19	1 25	NET	UPS / FedEx SHIP Wt.	Freight SHIP Wt.	A	B	E CRANK	E POWER	F CRANK	F POWER
C1514-17-18	1300 396	325 99	150 46	75 23	23 10	65* 30	58 26	11 279	6 152	17.5 445	19 483	18 457	15.5 394	9.5 241
C1520-17-18	-	650 198	300 91	150 46	25 11	80* 36	60 27	17 432	12 305	17.5 445	19 483	24 610	21.5 546	15.5 394
C1526-17-18	-	900 274	450 137	225 69	27 12	98* 45	62 28	23 584	18 457	17.5 445	19 483	30 762	27.5 699	21.5 546
C1530-17-18	-	1000 305	550 168	275 84	29 13	110* 50	64 29	27 686	22 559	17.5 445	19 483	34 864	31.5 800	25.5 648

Notes:

- Specifications subject to change.
- Upon request, reels can be supplied with drum lengths other than shown and with disc sizes in other diameters.
- Dimensions reflect pressed frames.
- Weights shown in chart are for crank rewind models. ADD these amounts for power rewind models (does not apply to FedEx or UPS):

	Net lbs/kg	Ship lbs/kg
Electric	18/8.2	18/8.2
Hydraulic	15/6.8	15/6.8
Air	15/6.8	15/6.8

- When ordering power rewind models, prefix model number with:
 - A** = Air Rewind – Supplied with control valve and 18" air hose.
 - E** = Electric Rewind – 12v and 24v DC rewind reels are supplied with switch and solenoid; 115v AC rewind reels are not supplied with switch but can be ordered separately.
 - HD** = Hydraulic Rewind – Not supplied with control valve.
- Finish:** Refer to page 3.
- Be sure to check dimensions and weights prior to ordering.**

*Dimensional weight applies when shipped as a parcel package (via FedEx or UPS Ground).
*** X, Y indicate mounting holes. See page 5.

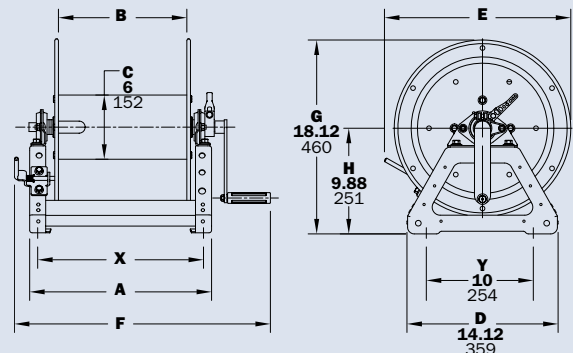

Crank rewind shown

Series C3200

• Hose • Rope • Cable • Wire

To handle single 1/2" through 1-1/2" O.D.

- A 4-1/2" x 9" (114mm x 229mm) opening in the drum to initiate winding.
- Designed for storage of long lengths of hose, cable, rope, wire or other materials.
- Choose disc rewind or removable direct crank rewind.
- Supplied with spring actuated pin lock.
- Optional divider discs can be placed at almost any point. Be sure to specify spacing of discs on your order.
- Rollers and roller mounting brackets are accessory items. Specify roller position.
- For power rewind, see Series C in cable reels catalog H0507-C.



Standard configuration with crank handle shown

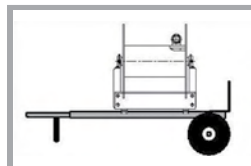

Optional Aluminum Hand Cart

4300-AL mounting available.

PARTS DRAWING – ISO 117

Model Number	Hose Capacity of Reel shown in feet /meter						Approx. Weight Crank Rewind shown in lb/kg		Reel Dimensions*** shown in inches/millimeter					
	O.D. in. mm	1/2 13	3/4 19	1 25	1-1/4 32	1-1/2 38	NET	SHIP	A	B	E CRANK	F CRANK	G	H
C3218-25-26-10.5	1000	450	225	125	90	85	127	15	9.5	24.75	22.75	27.88	15.5	7
	305	137	69	38	27	39	58	381	241	629	578	708	394	178
C3228-25-26-10.5	-	1000	500	325	200	109	151	25.5	20	24.75	33.25	27.88	15.5	17.5
	-	305	152	99	61	49	68	648	508	629	845	708	394	445
C3234-25-26-10.5	-	1300	650	400	275	122	164	31.5	26	24.75	39.25	27.88	15.5	23.5
	-	396	198	122	84	55	74	800	660	629	997	708	394	597

Notes:

1. Specifications subject to change.
 2. Upon request, reels can be supplied with drum lengths other than shown and with disc sizes in other diameters.
 3. Dimensions reflect pressed frames.
 4. Series C3200 requires 3-1/2" clearance to remove crank handle.
 5. Subtract 5" from "F" dimension for disc rewind on C3200 Series.
 6. **Finish:** Refer to page 3.
 7. **Be sure to check dimensions and weights prior to ordering.**
- *** X, Y indicate mounting holes. See page 5.

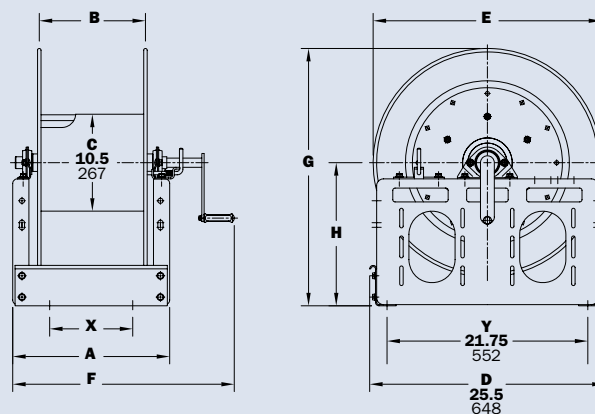

Series **CHC**

• Chlorine • Pesticides • Fertilizers • Acid

Series CHC reels are used in chemical distribution/delivery for a variety of applications including: commercial/community pools, water parks, toxic waste recycling, bulk handling of acid, bleach, chlorine, pesticides, fertilizers and more.

To handle single 3/8" through 1-1/2" I.D.

- Handles 3/8" through 1-1/2" ID hose, ranging from 50 ft up to 200 ft in length. For larger ID hose please consult factory.
- Standard inlet: CPVC swivel joint resists corrosion and provides longer life.
- Standard fluid temperatures from -33° F to +200 °F (-36° C to +93° C). Optional temperature ratings available - consult factory.
- Slotted hub for hose passage, with drum cut out on opposite side from the swivel joint. Fluid will not come in contact with metal, as the hose serves as the sole fluid path.
- Manual or power rewind with optional auxiliary crank rewind on specific models.
- Special swivel mounting bracket with clamp to hold the CPVC swivel in place.
- Reels can be constructed of painted steel or stainless steel.



Detailed cut-out of slotted hub to show hose passage



Close-up of CPVC swivel, clamp and mounting bracket.

ORDERING INFORMATION:

Contact Hannay Reels Inside Sales Department for more information. Be sure to provide detailed specifications on hose type, ID/OD, fluid and application information when ordering.

Series **SNC**

• Lawn Care • Pest Control • Fertilizer Mixes

To handle single 3/8" through 5/8" I.D. hose.

- Lightweight, low-profile reels designed for hose lengths up to 500 ft.
- Primarily 304 SST construction, including discs, axle hub, and welded frame.
- Non-SST components: Drum (Aluminum), Swivel Joint and Bearings (Plated).
- Manual (direct crank) reels include both pin lock and 3-position cam-lock drag brake.
- Electric rewind reels (denoted by letter 'E' at end of model) feature plated chain/sprocket drive with guard.
- Standard inlet: 90° full-flow swivel, 1/2" FNPT threads. Standard outlet: 1/2" FNPT threads.
- Standard pressure rated to 3000 psi (207) bar. Standard fluid temperatures from +32° F to +400 °F (0° C to +204° C).
- Consult factory for other pressures and temperatures.

Options:

- 304 SST stackable frame.
- SST rollers and roller mounting brackets.
- Drum, swivel joint and bearings all upgradeable to SST.
- Power rewind reels: Motor available in 12 or 24VDC, as well as 115VAC.

Model SNC-18 ▶

manual rewind reel with optional rollers



◀ Model SNC-18E

Electric Rewind (E) (hose not included)



Model SNC-18 ▶

two manual rewind reels shown with optional stacking frame and rollers

Model Number	Hose Capacity of Reel shown in feet /meter				Approx. Weight shown in lb/kg			Reel Dimensions*** shown in inches/millimeter				
	I.D. in.	3/8	1/2	5/8	NET	UPS/ FedEx SHIP Wt.	Freight SHIP Wt.	A	B	E	F	X
	mm	10	13	16								
SNC-12	300	200	125	29	80*	64	17	12	17.5	25.62	15.5	
	84	53	38	13	36	29	432	305	445	651	394	
SNC-18	400	300	200	31	98*	66	23	18	17.5	31.62	21.5	
	122	91	61	14	45	30	584	457	445	803	546	
SNC-22	500	400	275	33	110*	68	27	22	17.5	35.62	25.5	
	152	114	84	15	50	31	686	559	445	905	648	
SNC-12E	300	200	125	47	80*	82	17	12	19	23	15.5	
	84	53	38	21	36	37	432	305	483	584	394	
SNC-18E	400	300	200	49	98*	84	23	18	19	29	21.5	
	122	91	61	22	45	38	584	457	483	737	546	
SNC-22E	500	400	275	51	110*	86	27	22	19	33	25.5	
	152	114	84	23	50	39	686	559	483	838	648	

Notes:

1. Specifications subject to change.
2. Other models available than those shown.
3. Dimension "F" is the overall length of standard model reels.
4. Electric rewind reels indicated with 'E' in model suffix (example - SNC-12E).
5. Be sure to check dimensions and weights prior to ordering.

NOTICE: A flexible connector must be used between the inlet pipe and the inlet swivel joint.

* Dimensional weight applies when shipped as a parcel package (via FedEx or UPS Ground).

*** X, Y indicate mounting holes.

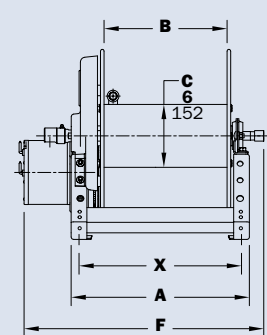
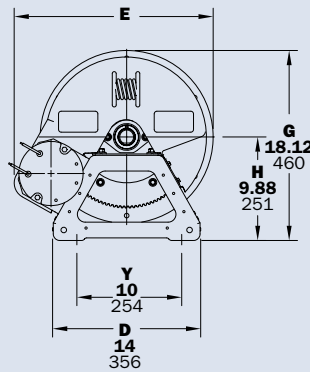

Electric rewind shown

Series **VAC4000**

• Shop Vacuum Applications • Car Detailing • Dust/Debris Collection Only

To handle single 1-1/2" I.D. industrial vacuum hose

- NOTE: Standard inlet/outlet are slip fit connections, not threaded connections.
- Includes permanently attached crank handle and cam-lock drag brake.
- Rollformed channel frame for heavy duty applications.
- Internal hub connection to fit hose cuff.

NOTE: These reels are NOT for solid or liquid suction. Please refer to our Pumper Cleaner catalog for vacuum reel options with solid or liquid applications



Standard configuration shown (hose not included).

Model Number	Hose Capacity of Reel shown in feet /meter		Approx. Weight shown in lb/kg			Reel Dimensions*** shown in inches/millimeter									
	I.D. in. mm	1-1/2 38	NET	UPS/ FedEx SHIP Wt.	Freight SHIP Wt.	A	B	C	D	E	F	G	H	X	Y
	O.D. in. mm	1.84 47													
VAC4020-17-18-8	25	38	82	73	17	12	8	18	16.50	24.88	18.13	9.88	9.50	14.25	
	8	17	37	33	431	305	203	457	419	632	460	251	241	362	
VAC4024-17-18-8	35	42	94	77	21	16	8	18	16.50	28.88	18.13	9.88	13.50	14.25	
	11	19	43	35	533	406	203	457	419	734	460	251	343	362	
VAC4028-17-18-8	50	46	98	81	25	20	8	18	16.50	32.88	18.13	9.88	17.50	14.25	
	15	21	45	37	635	508	203	457	419	835	460	251	445	362	

Notes:

1. Specifications subject to change.
2. Upon request, reels can be supplied with drum lengths other than shown.
3. Dimension "F" is the overall length of standard model reels.
4. **Be sure to check dimensions and weights prior to ordering.**

* Dimensional weight applies when shipped as a parcel package (via FedEx or UPS Ground).

*** X, Y indicate mounting holes. (Also applies for external mounting brackets.)

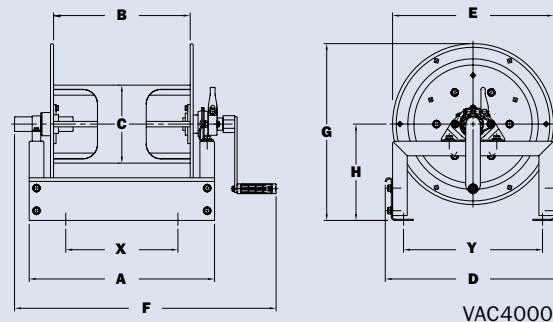

VAC4000

Series VACN900/VAC900

• Shop Vacuum Applications • Car Detailing • Dust/Debris Collection Only

VACN900 Standard Features:

- To handle 1-1/2" ID industrial vacuum hose. NOTE: Standard inlet/outlet are slip fit connections, not threaded connections.
- N-series has a narrow frame and compact mounting base, allows for different mounting options: floor, ceiling or wall.
- Non-sparking ratchet assembly locks hose at different payout lengths and 4-way roller assembly to guide hose.

VAC900/VAC2900 Standard Features:

- VAC900: to handle 1-1/2" ID vacuum hose; VAC2900: to handle 2" ID vacuum hose. NOTE: Standard inlet/outlet are slip fit connections, not threaded connections.
- Roll-formed channel frame for heavy-duty applications, allows different mounting options: floor, ceiling or wall.
- Non-sparking ratchet assembly locks hose at different payout lengths and 4-way roller assembly to guide hose.

NOTE: These reels are NOT for solid or liquid suction. Please refer to our Pumper Cleaner catalog for vacuum reel options with solid or liquid applications.



◀ **VACN900 Series**
Standard SR configuration shown
(hose not included)



VAC900 Series ▶
Optional TR configuration shown
(hose not included)

Model Number	Hose Capacity of Reel shown in feet / meter			Approx. Weight shown in lb/kg		Standard Roller Assy.	Reel Dimensions*** shown in inches/millimeter								
	I.D. in. / mm	1-1/2 / 38	2 / 51	NET	SHIP		A	B	D	E	F	G	H	X	Y
	O.D. in. / mm	1.84 / 47	2.34 / 59				12	6	12	24	13.25	24	12.63	10	10
VACN918-23-24-10.5L	25 / 8	-	-	60 / 27	95 / 43	N306	12	6	12	24	13.25	24	12.63	10	10
VACN920-23-24-10.5L	35 / 11	-	-	62 / 28	97 / 44	N308	14	8	12	24	15.25	24	12.63	12	10
VAC920-28-29-10.5J	50 / 15	-	-	76 / 34	111 / 50	R308	13.25	8	28.5	26.75	16.5	28.25	14.88	8.5	23.25
VAC2920-28-29-10.5J	-	25 / 8	-	77 / 35	112 / 51	R2308	13.25	8	28.5	26.75	16.75	28.25	14.88	8.5	23.25
VAC2922-28-29-10.5J	-	35 / 11	-	79 / 36	113 / 51	R2310	15.25	10	28.5	26.75	18.75	28.25	14.88	10.5	23.25
VAC2920-33-34-10.5J	-	50 / 15	-	92 / 42	127 / 58	R2308	13.25	8	33	31.75	16.75	33.63	17.75	8.5	27.75

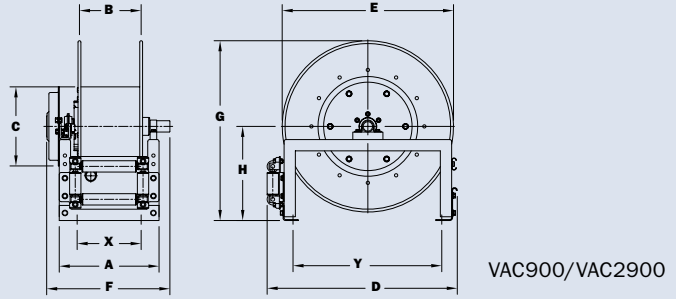
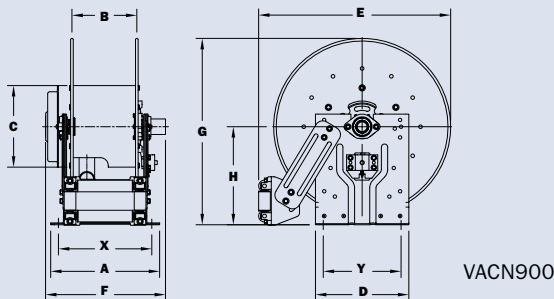

Available Roller Positions

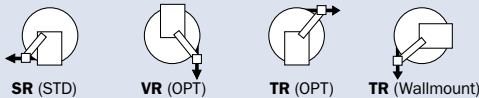

Notes: A hose stop is necessary to keep spring from unwinding.

1. Specifications subject to change.
2. Reel models and capacities shown are for standard drag applications; for vertical lift applications, consult factory.
3. Be sure to check dimensions and weights prior to ordering.

*** X, Y indicate mounting holes.

Find reels for every need.

Learn more about all of our reels, including specs, drawings, and even how to select the right reels and accessories for your industry.

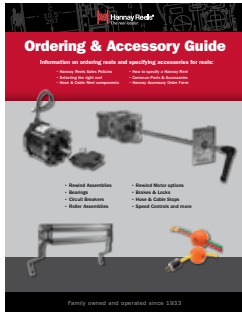

Ordering & Accessory Guide

- Selecting the right reel
- Reel components
- Available accessories
- How to spec and order reels and accessories
- Ordering options
- Hannay Reels policies

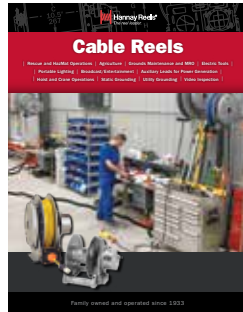

Cable Reels

- Electric Tools
- Crane operations
- Portable Lighting
- Live and storage reels
- Video/Broadcast
- Static and Utility grounding reels

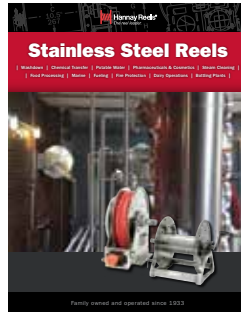

Stainless Steel Reels

- Washdown/Power Wash
- Food & Beverage Processing
- Chemical Processing
- Potable Water
- Fueling
- Steam Cleaning



Welding Reels

- Mobile and fixed installations
- Arc welding
- Gas welding
- Cutting operations

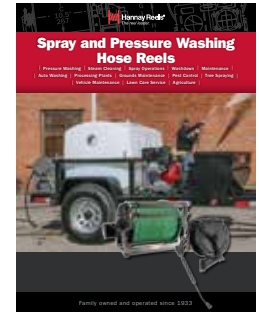

Spray and Pressure Washing Hose Reels

- Washdown/Power Wash
- Pest Control/Fertilizers
- Air/Water/Grease
- Steam Cleaning
- Spray operations
- Portable hose reels

View all our reel catalogs online at hannay.com



Family owned and operated since 1933, Hannay Reels is the world leader in both OEM and aftermarket applications. Hannay offers thousands of standard hose reel and cable reel models, as well as unmatched custom capabilities. We can easily and affordably customize a reel to meet your exact specifications – built to last, delivered fast. Additional catalogs are available through your local Hannay Reels dealer or online at hannay.com.



553 State Route 143 | Westerlo, New York 12193
Email: reels@hannay.com | hannay.com



All Hannay reels are constructed of quality heavy gauge steel (optional aluminum or stainless steel also available on most models).

